

Concealed
cam-action
door closer system

DORMA ITS 96

Concealed cam-action door closer system DORMA ITS 96



Flawless beauty

To ensure that prestigious doors retain all their inherent attraction, they can now be fitted with a concealed cam-action door closer system – the DORMA ITS 96. This is the first system of its kind, one which can be integrated in the door leaf and frame with the utmost elegance. Where the emphasis is on appearance, the disappearing DORMA System ITS 96 is the ideal solution for your doors: Advanced technology accommodated within the tightest of spaces, totally out of sight and featuring the proven heart-shaped cam which characterises all

DORMA slide channel door closers.

The cam is literally at the heart of DORMA slide channel door closers – it guarantees secure closing while at the same time offering a rapidly decreasing opening force so that even children, the elderly and disabled people encounter only minimum resistance as they open the door. However, it is not only these categories of user who benefit. Thanks to the substantial reduction in effort required, this technology offers the ultimate in user convenience to all.

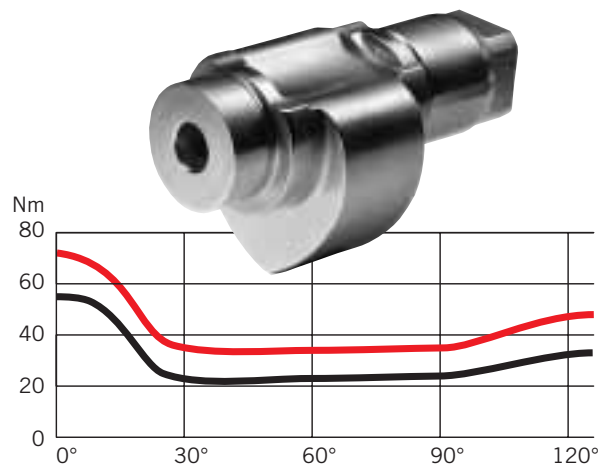

Force profile of an ITS 96 cam action door closer (Size EN 3 – 6, max. closing strength setting)

— Opening force
— Closing force



Contents

	Page
DORMA ITS 96	
Features and functions	4
DORMA ITS 96	
Application and installation	6
DORMA G 96 N20	
Standard slide channel design	8
DORMA RF	
Hold-open unit	8
DORMA G 96 EMF	
Slide channel with electro-mechanical hold-open	10
DORMA G 96 GSR	
Slide channel door co-ordinator	12
DORMA G 96 GSR-EMF	
Slide channel door co-ordinator with electro-mechanical hold-open	14
DORMA RMZ-K/S, DORMA RM	
Frame-mounted and ceiling-mounted smoke detectors	20
Accessories	22
Hold-open systems	
Regulations and information	25
Range of equipment and optional accessories	26



This CD-ROM contains the necessary information concerning DORMA ITS 96 System. Orders for the CD-ROM can be placed online under www.dorma.com

Uncompromising technical sophistication

The DORMA ITS 96 has ushered in a new era in door closer technology. The closer body and slide channel are so compact that they can be installed out of sight in doors and their frames. These devices offer the same high quality expected of DORMA door closers, as characterised by their ease of operation for the user, and wide range of functions. Thanks to the exceptionally

slender dimensions of the unit, the DORMA ITS 96 can be installed in virtually all doors with thicknesses of 40 mm or more, and offers all the advantages of quality assured manufacture with third-party auditing.



Plus points...

...for the trade

- Low inventory costs and reduced stocking requirements thanks to streamlined modular system and separate packaging of closer body and slide channel assemblies.
- Tailor-made applications with special accessories.

...for the installer

- Non-handed system.
- Can be incorporated within the door pre-fabrication process, allowing complete installation in the factory.
- Easy adjustment of the closing strength, closing speed and latch action after hanging of the doors.

...for the specifier/architect

- Unblemished appearance of prestige doors thanks to concealed installation.
- Ideal for doors integral to the interior design.

...for the user

- Optimum protection against vandalism thanks to the concealed installation.
- Enhanced user convenience and fully controlled, reliable closing with adjustable latch action.
- Cushioned limit stay with progressive damping for protection of wall and door.

Data and features ITS 96

Variable closing force	Spring strength	EN 2-4	EN 3-6
Standard doors	up to 1100 mm up to 1400 mm	• -	• •
External doors, outward opening		-	-
Fire and smoke check doors	up to 1100 mm up to 1400 mm	• -	• •
Door leaf thickness	equal to/greater than 40 mm equal to/greater than 50 mm	• •	- •
Max. door leaf weight in kg		100	180
Non-handed design (closer)		•	•
Arm	Slide channel	•	•
Closing force variable by means of adjustable screw		•	•
Closing speed adjustable by means of valve		•	•
Latching speed adjustable by means of valve		•	•
Cushioned limit stay, mechanical		•	•
Delayed action		-	-
Hold-open		○	○
Max. door opening angle (depends on door design)		approx. 120°	
Weight in kg		1.3	2.5
Dimensions in mm	Length Width Height	277 32 42	291 39.5 51
Door closer tested to EN 1154 A		•	
Hold-open devices tested to EN 1155		•	
Door co-ordinators tested to EN 1158		•	

• Yes - No ○ Option

Further information

Additional information about many of our products is available from a range of electronic media (Internet, CD-ROM, diskettes). The abbreviated codes next to the computer symbol indicate the search terms.

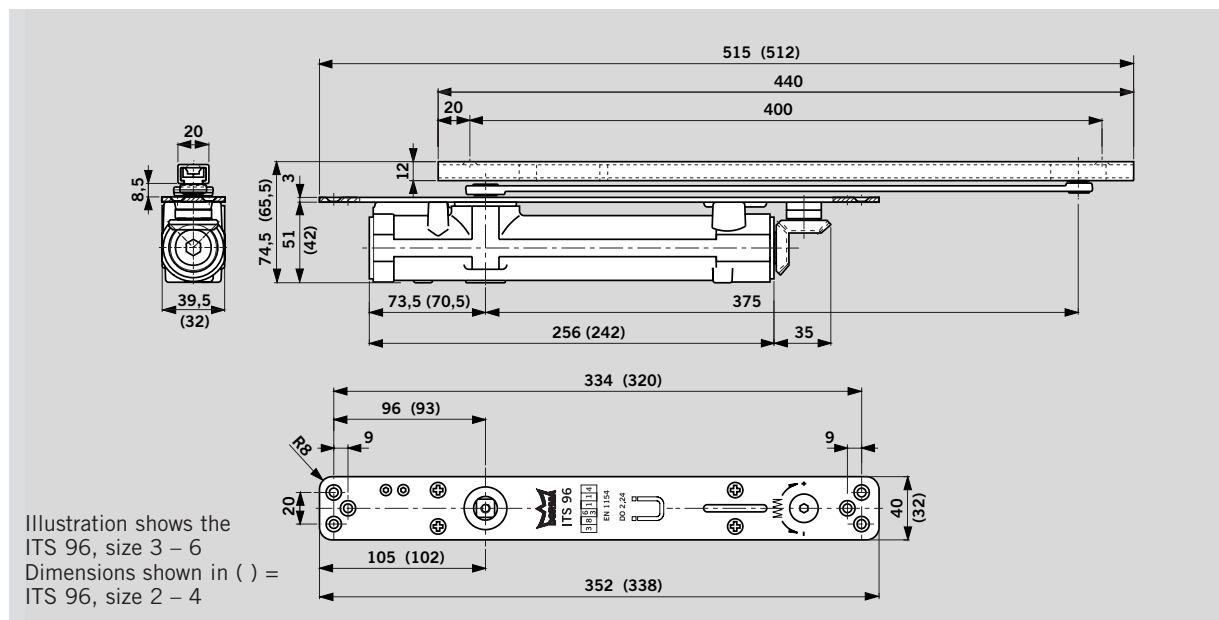

Adjustment of settings

The functions of the DORMA ITS 96 can be individually adapted to the local conditions of each application. The closing strength can be easily varied in accordance with the door width via the adjustment screw accessible from the top. The closing speed and the latch action can likewise be modified at any time using adjustment screws at the top, even after the door has been hung.

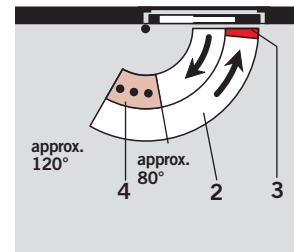
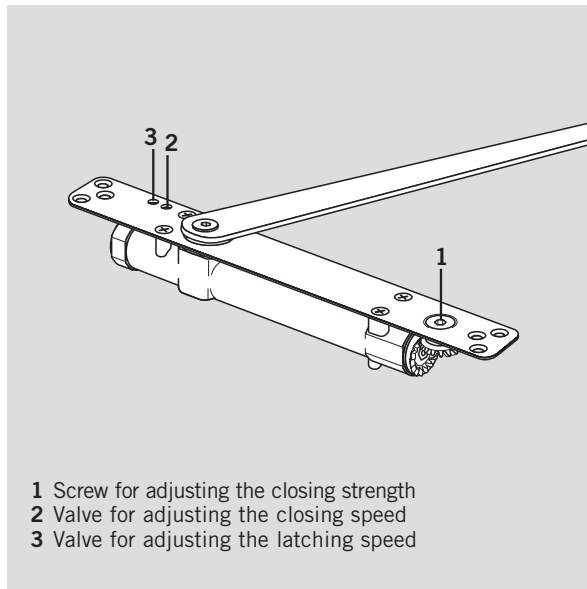

- 2 Fully controlled closing with adjustable speed
- 3 Adjustable latch action
- 4 Cushioned limit stay

Cushioned limit stay

The integrated mechanically cushioned limit stay of the DORMA ITS 96 is progressively damped to protect the wall and doors from the damage arising from the door being opened too wide (under conditions of normal usage). It can be adjusted to an opening angle between approx. 80° and max. 120°. **The cushioned limit stay feature is not an overload protection device and in many cases cannot replace a doorstop.**

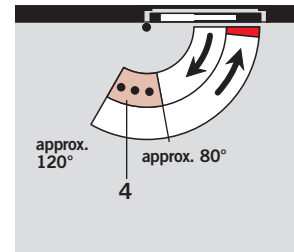
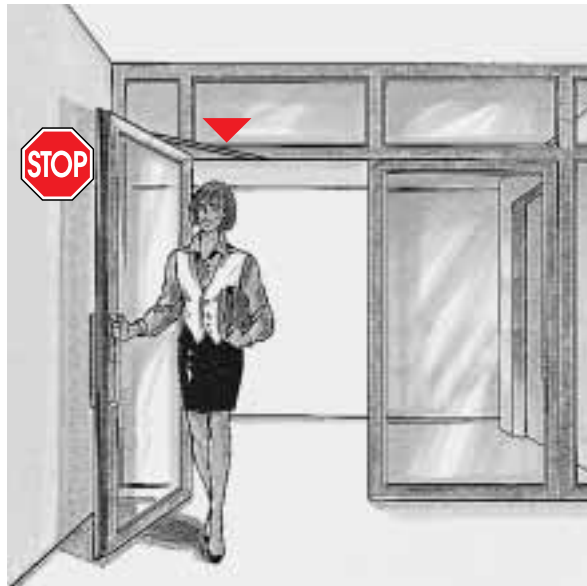

- 4 Cushioned limit stay

F Approval certification

The DORMA ITS 96 is approved by the State Material Testing Authority, Dortmund, in accordance with EN 1154 A. Additionally, the model size EN 2 – 4 and EN 3 – 6 has CERTIFIRE approval for use on timber FD30 and FD60 doors (code ITT), when installed with the approved intumescent gasket set for FD30 or FD60 supplied by DORMA UK. The length, width and height of mortice for the body and slide channel must be increased by 2 mm to accommodate the gasket.

Specification text

Cam-action door closer integrated in the door leaf or frame, tested to EN 1154 A, with rapidly decreasing opening torque/force. Closing strength, closing speed and latch action adjustable. Non-handed, with slide channel... (see pages 8 – 15)

Size

- EN 2 – 4
- EN 3 – 6

Make DORMA ITS 96

- ITS96/2-4
- ITS96/3-6



The DORMA ITS 96 concealed cam action door closer system is suitable for various door designs and different rebate clearance dimensions. This is achieved through the combination of different spindle lengths

available with the closer and the universal K8/K12 slide channel. Installation suggestions for the DORMA ITS 96 door closer system relating to the most common door types are available from DORMA on request.

G 96 N20
G 96 EMF
G 96 GSR/GSR-EMF

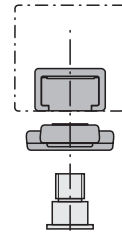

K 8

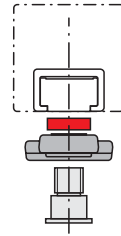

K 12

ITS 96 2-4
ITS 96 3-6

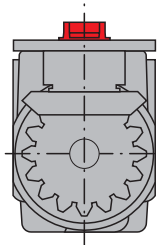

ITS 96 2-4
ITS 96 3-6
with 4 mm
extended spindle

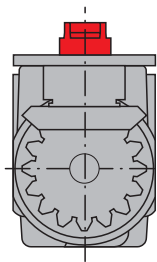

ITS 96 2-4
ITS 96 3-6
with 8 mm
extended spindle

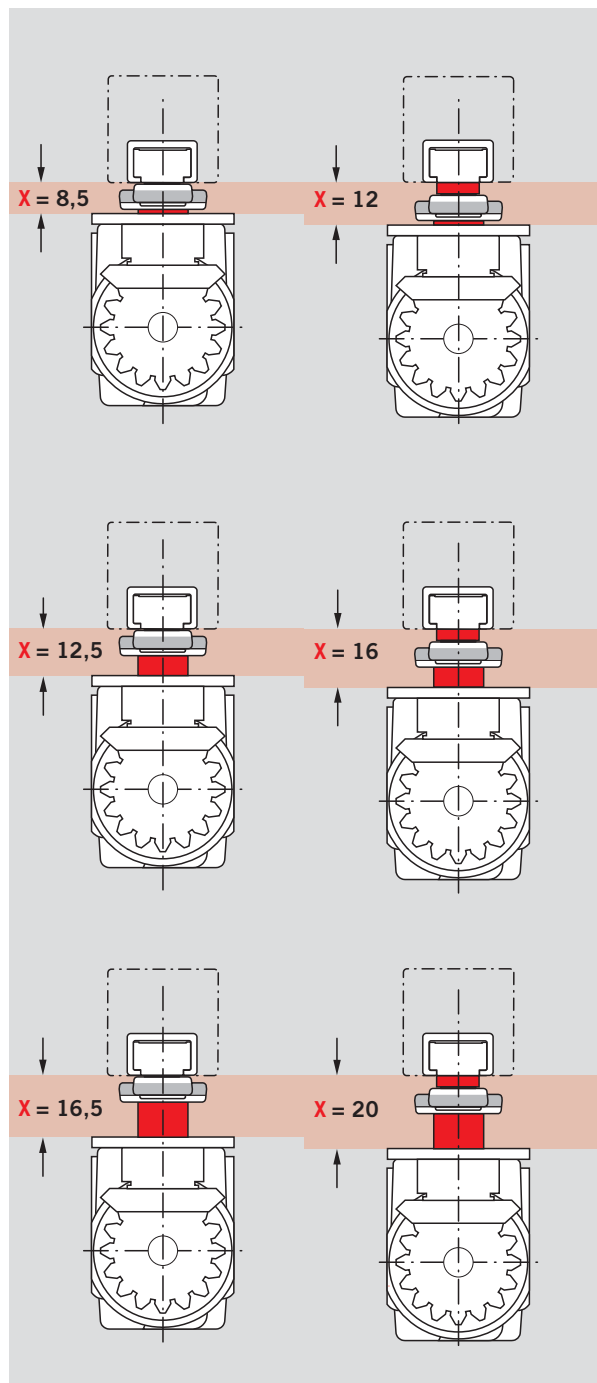
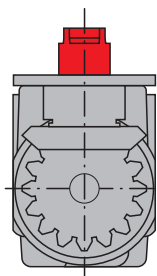

Timber door, flush-closing, clearance 8.5 mm, with ITS 96 EN 3-6 and slide channel G 96 N20 K8.

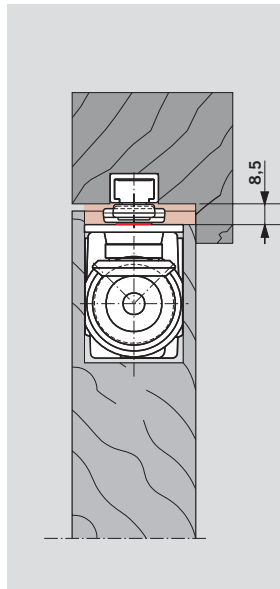

Timber door with steel frame, flush closing, clearance 12.5 mm, with ITS 96 EN 3-6, 4 mm extended spindle and slide channel G 96 N20 K8.

 Please check dimensions carefully

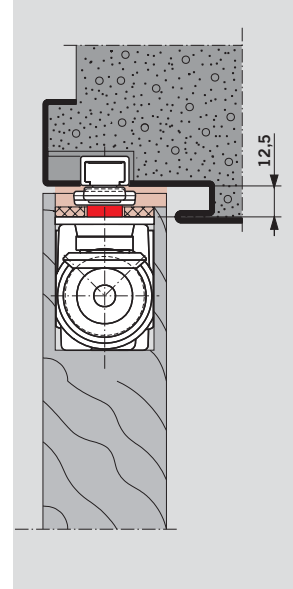

Tubular steel frame door, flush-closing, clearance 12 mm, with ITS 96 EN 3-6 and slide channel G 96 N20 K12.

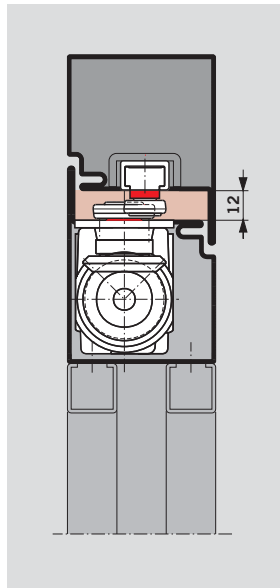

Aluminium tubular frame door, flush-closing, clearance 16 mm, with ITS 96 EN 3-6, 4 mm extended spindle and slide channel G 96 N20 K12.

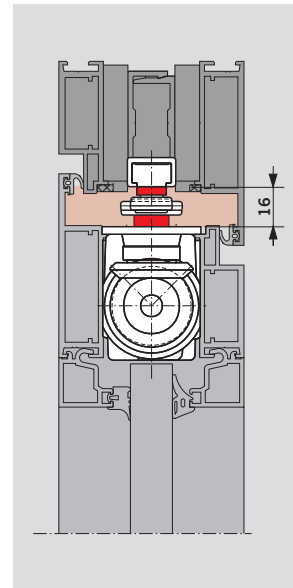

Hollow steel door with steel frame, over-rebated, clearance 12 mm, with ITS 96 EN 3-6, 4 mm extended spindle and slide channel G 96 EMF K8.

 Please check dimensions carefully

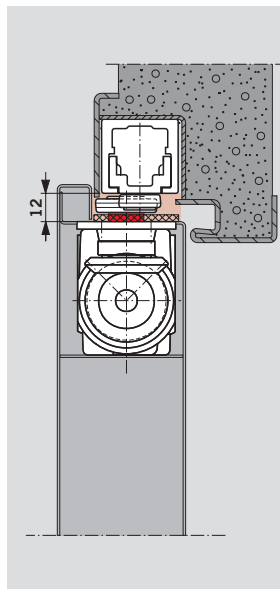

Timber door with solid frame, double rebated, clearance 20 mm, with ITS 96 EN 3-6, 8 mm extended spindle and slide channel G 96 N20 K12.

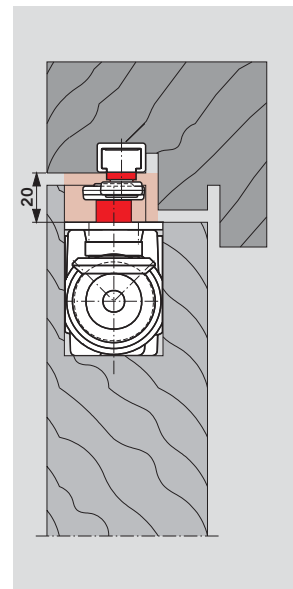

Standard model

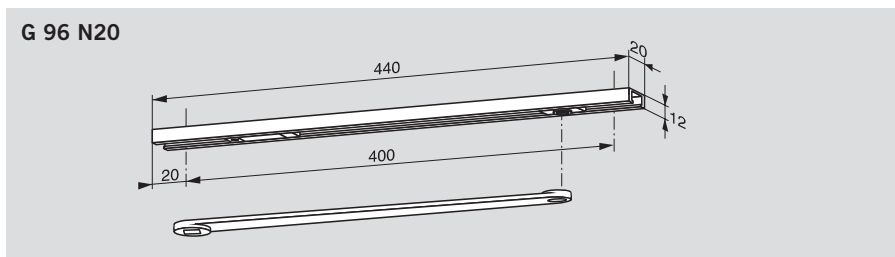

The **DORMA G 96 N20** slide channel pack includes the arm, slide channel, slide block, cushioned limit stay and fixing screws, and can be combined with both door closer sizes in the DORMA ITS 96 range.

The DORMA G 96 N20 slide channel is adjustable to K8/K12.

F Approval certification

The G 96 N20 slide channel is tested to EN 1154 A in conjunction with the DORMA ITS 96. Additionally, it has CERTIFIRE approval for use on timber FD30 and FD60 doors (code ITT), when installed with the approved intumescent gasket set for FD30 or FD60 supplied by DORMA UK. The length, width and height of mortice for the slide channel must be increased by 2 mm to accommodate the gasket.

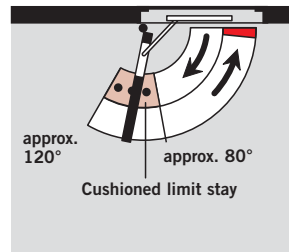

Specification text

DORMA ITS 96 ... door closer (see pages 4 and 5) with slide channel G 96 N20

Version

- LH (ISO 6) K8/K12
- RH (ISO 5) K8/K12

Make DORMA ITS 96 N20

- ITS96/2-4
- ITS96/3-6

Hold-open unit

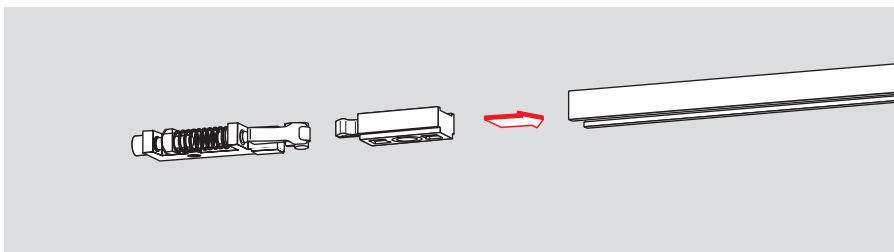

The **DORMA RF** hold-open unit enables doors to be securely held without any fall-back at precisely the required position up to an opening angle of approx. 120°. The pull-off force can be adjusted to any door situation. The DORMA RF

mechanism is non-handed and has been specifically designed for retrofitting to the G 96 N20 slide channel.

Not for fire and smoke check doors.

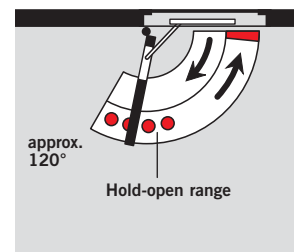

Accessories

- Hold-open unit DORMA RF G 96 N20
- ITS96RF/2-4
- ITS96RF/3-6

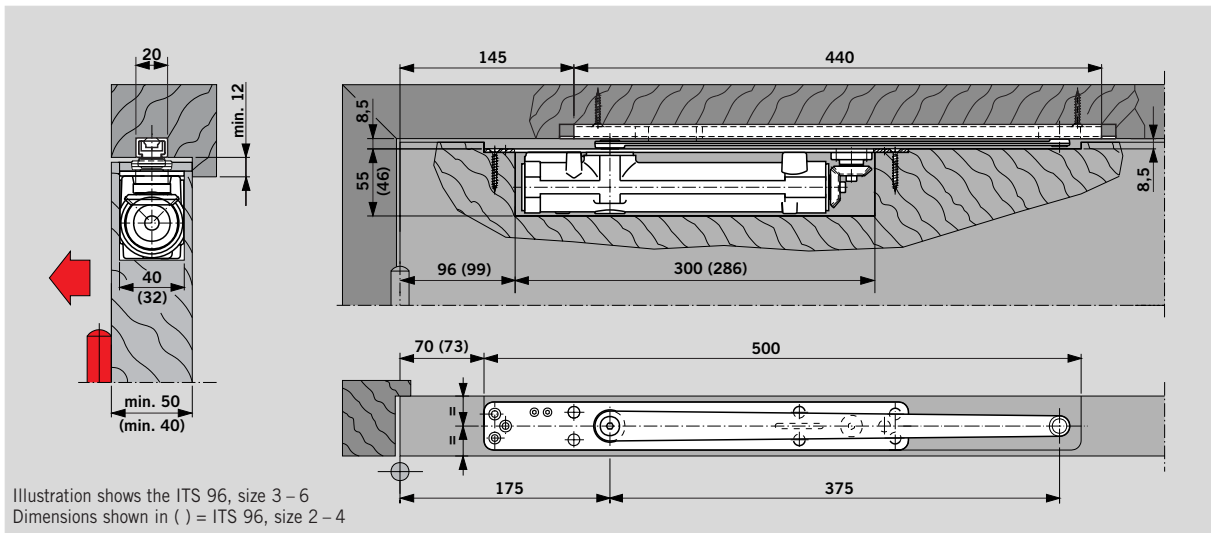

DORMA ITS 96 door closer with DORMA G 96 N20 slide channel in a **timber door**
Example: Anticlockwise-closing (ISO 6) door; mirror image applies to clockwise-closing (ISO 5) doors.

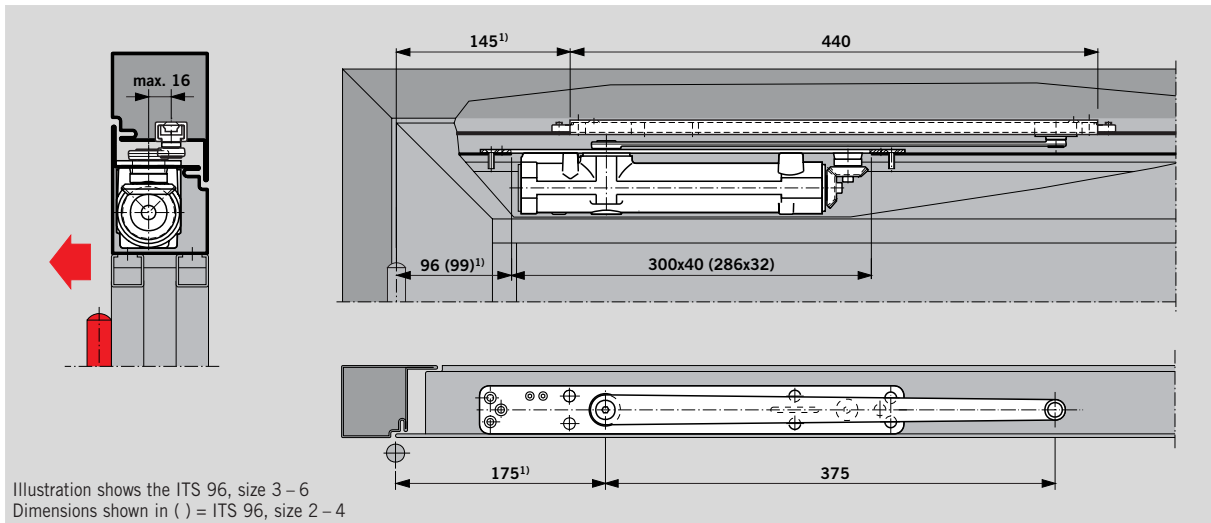

DORMA ITS 96 door closer with DORMA G 96 N20 slide channel in an **aluminium framed door**
Example: Anticlockwise-closing (ISO 6) door; mirror image applies to clockwise-closing (ISO 5) doors.
1) Add 25 mm for aluminium profile frames with corner-angle reinforcement.

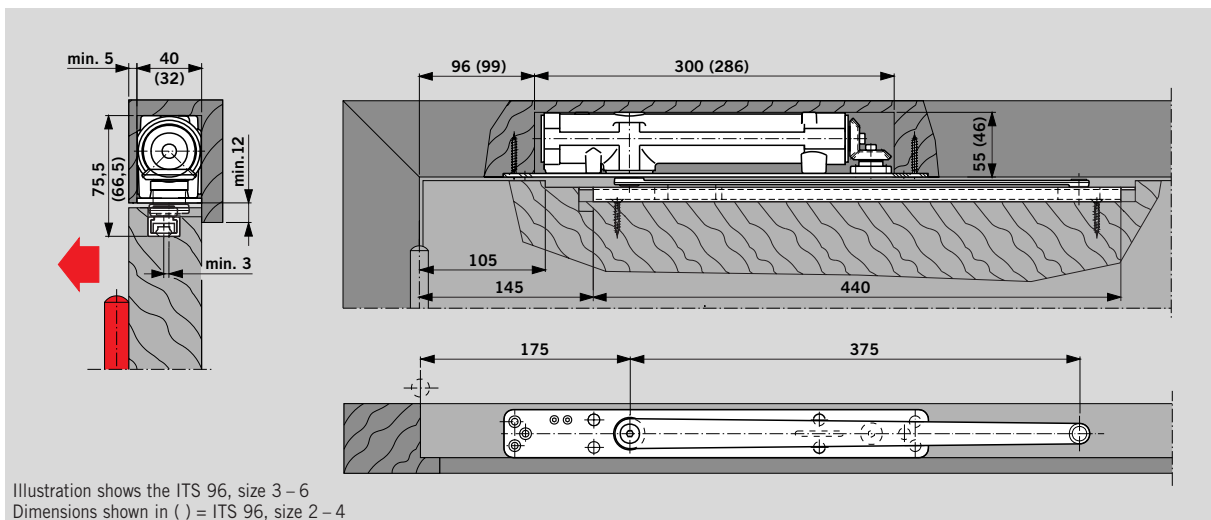

DORMA ITS 96 door closer with DORMA G 96 N20 slide channel in a **timber door-transom fixing**
Example: Anticlockwise-closing (ISO 6) door; mirror image applies to clockwise-closing (ISO 5) doors.

Electro-mechanical hold-open

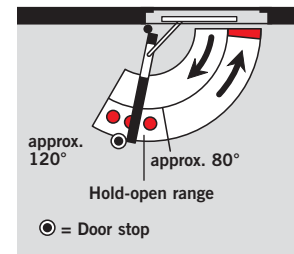
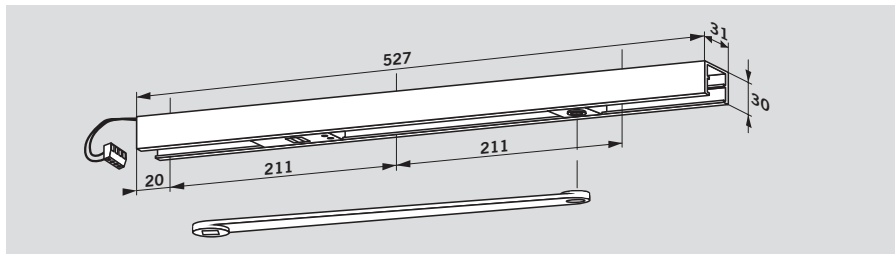

The **DORMA G 96 EMF** slide channel assembly enables the door to be held open securely at a pre-selected position without fall-back. The hold-open point can be adjusted within an opening angle of approx. 80° and 120°.

Note:

The hold-open point also constitutes the max. door opening angle (position door stop accordingly).

In the event of an alarm or a fault in the power supply, the hold-open is released and the door is closed by the door closer. The release is triggered by a signal from external smoke detectors (e.g. DORMA RMZ-K/S or DORMA RM). The release force for the hold-open mechanism can be adjusted without tools and is rated to ensure that the door can also be easily released manually.

The DORMA G 96 EMF slide channel assembly comprises the arm, slide channel, slide block, electro-mechanical hold-open unit and fixing screws, and can be combined with both door closer sizes in the DORMA ITS 96 range. In the case of particularly large and heavy doors (over 1250 mm), we recommend that DORMA EM hold-open magnets be employed instead of the electro-mechanical hold-open unit.

Specification text

DORMA ITS 96 ... door closer (see pages 4 and 5) with G 96 EMF K8/K12 slide channel assembly, with integrated 24 V DC electro-mechanical hold-open, tested to EN 1155. Hold-open point (80° – 120°) and release force adjustable. Approved by the Institute for Building Technology, Berlin, for general use in hold-open systems. Acceptance inspection of the system is mandatory in Germany.

Technical data

Operating voltage:	24 V DC, ± 15%
Power input:	1.4 W
Rated for continuous duty:	100%
Release force:	Adjustable

Version

- LH (ISO 6) K8/K12
- RH (ISO 5) K8/K12

Make DORMA ITS 96 EMF

- ITS96EMF/2-4
- ITS96EMF/3-6

Example application for a hold-open system

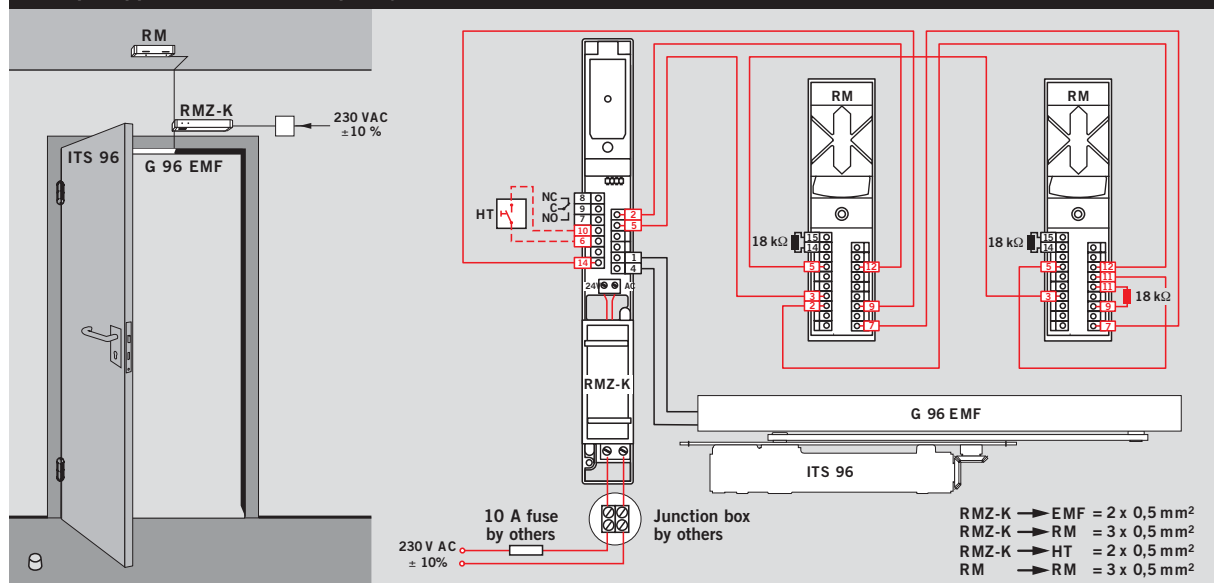

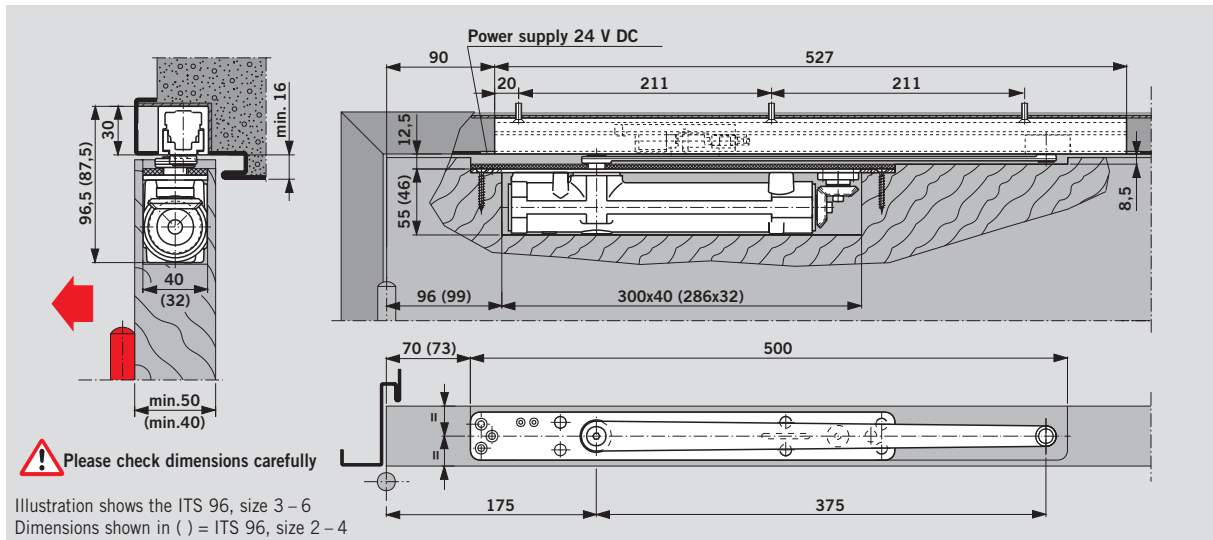

DORMA ITS 96 door closer with DORMA G 96 EMF side channel assembly in a **timber door**
Example: Anticlockwise-closing (ISO 6) door; mirror image applies to clockwise-closing (ISO 5) doors.

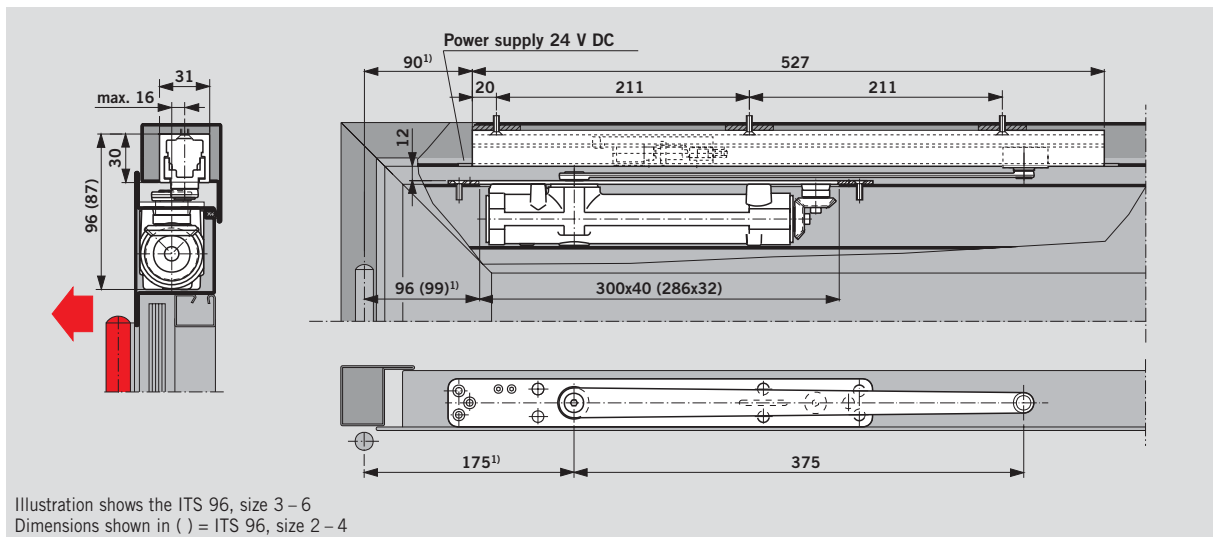

DORMA ITS 96 door closer with DORMA G 96 EMF side channel assembly in an **aluminium framed door**
Example: Anticlockwise-closing (ISO 6) door; mirror image applies to clockwise-closing (ISO 5) doors.
¹⁾ Add 25 mm for aluminium profile frames with corner-angle reinforcement.

F Approval certification

The DORMA ITS 96 EMF has been tested by the State Material Testing Authority, Dortmund, to EN 1155, Electrically Powered Hold-open Devices.

Regulations/Information

The use of hold-open devices may be subject to certain conditions – see page 25.

Door co-ordinator

The **DORMA G 96 GSR** slide channel with integral door co-ordinator for pairs of doors ensures that the active leaf always closes after the inactive leaf.

The DORMA G 96 GSR slide channel door co-ordinator features a push rod clamping system. As this system operates independently of door closer hydraulics, it offers maximum safety and reliability.

An overload release protects the door co-ordinator and the door set from damage. The DORMA G 96 GSR can be combined with both door closer sizes of the DORMA ITS 96 range.

Version/Function	Door width (mm)	Door leaf thickness min. (mm)	Closer size ITS 96
GSR Door co-ordinator	1400 – 2200	40	2 – 4
	1400 – 2800	50	3 – 6

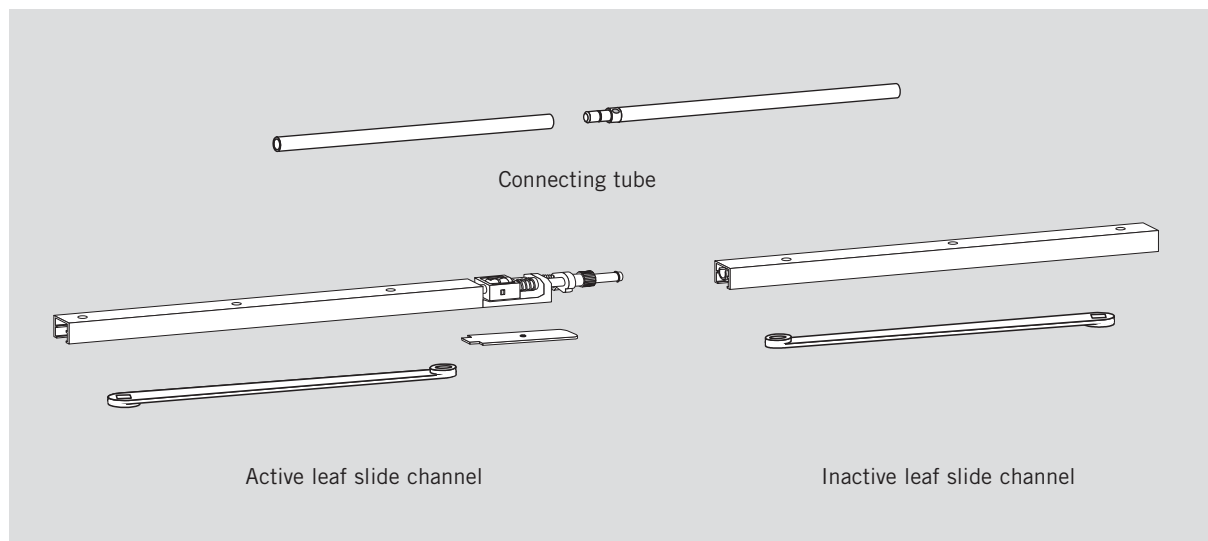

A DORMA G 96 GSR slide channel door co-ordinator encompasses an active leaf and an inactive leaf slide channel with cushioned limit stay, a connecting tube, a cover for the co-ordinator mechanism on the active leaf slide channel, and two arms.

F Approval certification

The DORMA ITS 96 GSR has been tested to EN 1158, Door Co-ordinator Devices by the State Material Testing Authority, Dortmund/Germany.

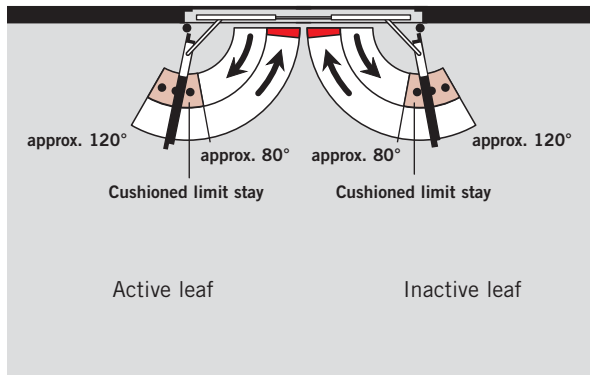

Specification text

DORMA ITS 96 ... door closer (see pages 4 – 5) with G 96 GSR K8/K12 slide channel, featuring integrated mechanical door co-ordinator using a push rod clamping system with overload release which operates independently of the closer hydraulics. Standard design – door leaves with no hold-open. Tested to EN 1158.

Approved by the Institute of Building Technology, Berlin, for general use in conjunction with fire and smoke check doors.

Make
DORMA ITS 96 GSR

 ITS96GSR/2-4
ITS96GSR/3-6

Example application

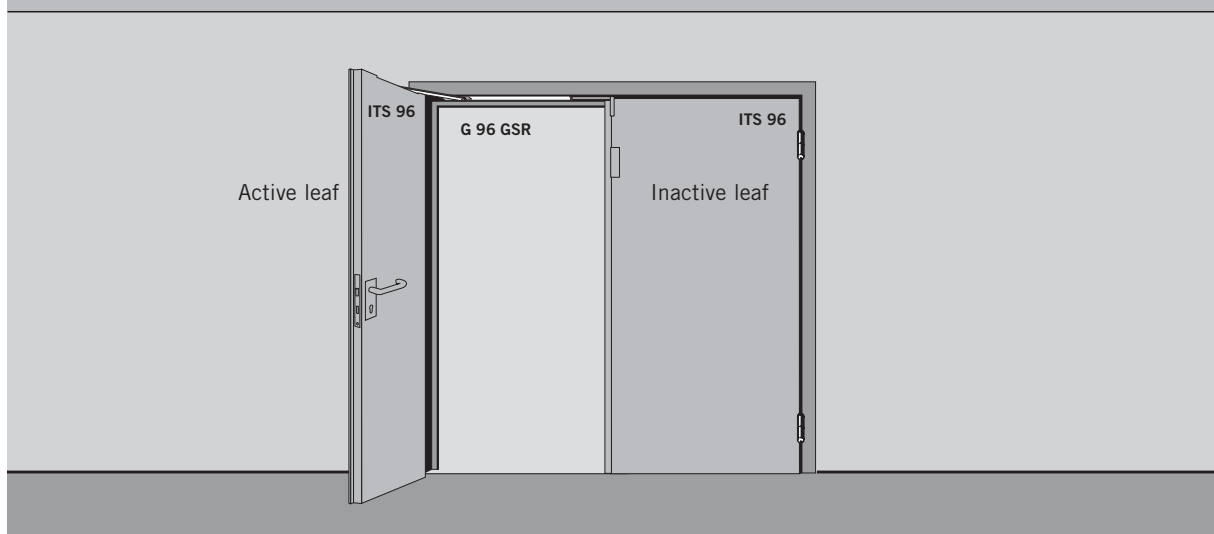

Door co-ordinator with electro-mechanical hold-open

This door co-ordinator not only ensures the correct closing sequence of pairs of doors, but also allows the door leaves to be individually held open by an electro-mechanical device. The hold-open point for both door leaves lies between approx. 80° and 120°.

Note:

The hold-open point also constitutes the max. door opening angle – position door stop accordingly.

In the event of an alarm or a fault in the power supply, the hold-open is released and the door is closed by the door closer. The release is initiated by a signal from external smoke detectors (e.g. DORMA RMZ-K/S or DORMA RM) or other fire alarm.

The release force for the hold-open mechanism can be adjusted without tools and is rated to ensure that the door can also be easily released manually.

The DORMA G 96 GSR-EMF slide channel door co-ordinator can be combined with both door closer sizes of the DORMA ITS 96 range.

In the case of particularly large and heavy doors (over 2500 mm), we recommended that DORMA EM hold-open magnets be employed instead of the electro-mechanical hold-open unit.

Regulations/Information

The use of hold-open devices may be subject to certain conditions – see page 25.

Version/Function	Door width (mm)	Door leaf thickness min. (mm)	Closer size ITS 96
GSR-EMF			
Door-coordinator and hold-open in both leaves	1400 – 2200	40	2 – 4
	1400 – 2800	50	3 – 6

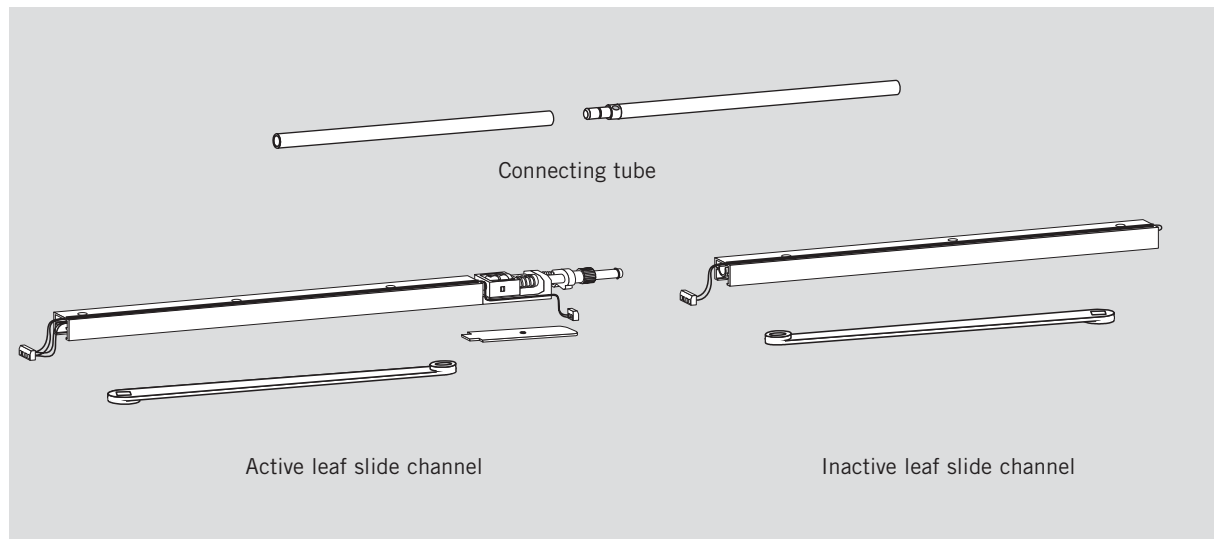

A DORMA G 96 GSR slide channel door co-ordinator encompasses an active leaf and an inactive leaf slide channel with electro-mechanical hold-open, a connecting tube, a cover for the co-ordinator mechanism on the active leaf slide channel, and two arms.

Technical data

Operating voltage:	24 V DC, $\pm 15\%$
Power input:	2.8 W
Rated for continuous duty:	100%
Release force:	Adjustable

F Approval certification

The DORMA ITS 96 GSR-EMF has been tested by the State Materials Testing Authority, Dortmund, to EN 1158, Door Co-ordinator Devices, and EN 1155, Electrically Powered Hold Open Devices.

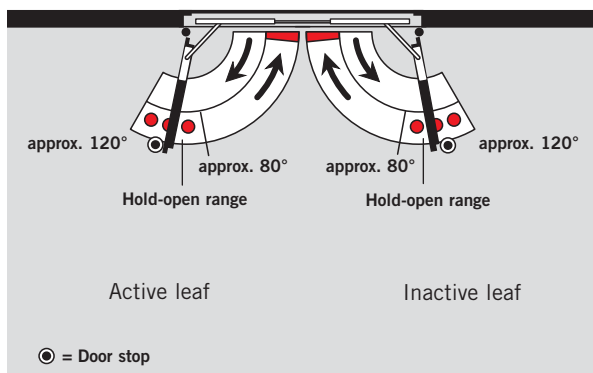

Specification text

DORMA ITS 96 ... door closer (see pages 4 – 5) with G 96 GSR-EMF K8/K12 slide channel, featuring integrated mechanical door co-ordinator using a push rod clamping system with overload release which operates independently of the closer hydraulics, with integrated electro-mechanical hold-open, 24 V DC. Hold-open point (80° – 120°) and release force adjustable. Tested to EN 1158 and EN 1155.

Approved by the Institute of Building Technology, Berlin, for general use in hold-open systems. Acceptance inspection of the system is mandatory in Germany.

Make
DORMA ITS 96 GSR-EMF

ITS96GSR-EMF/2-4
ITS96GSR-EMF/3-6

Example application, hold-open system

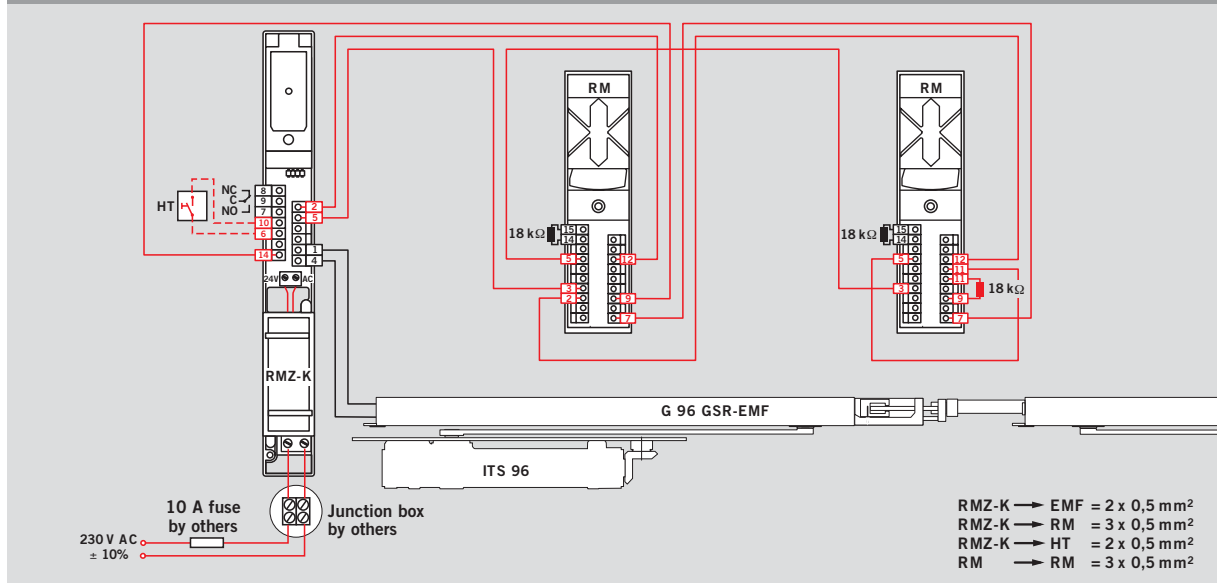
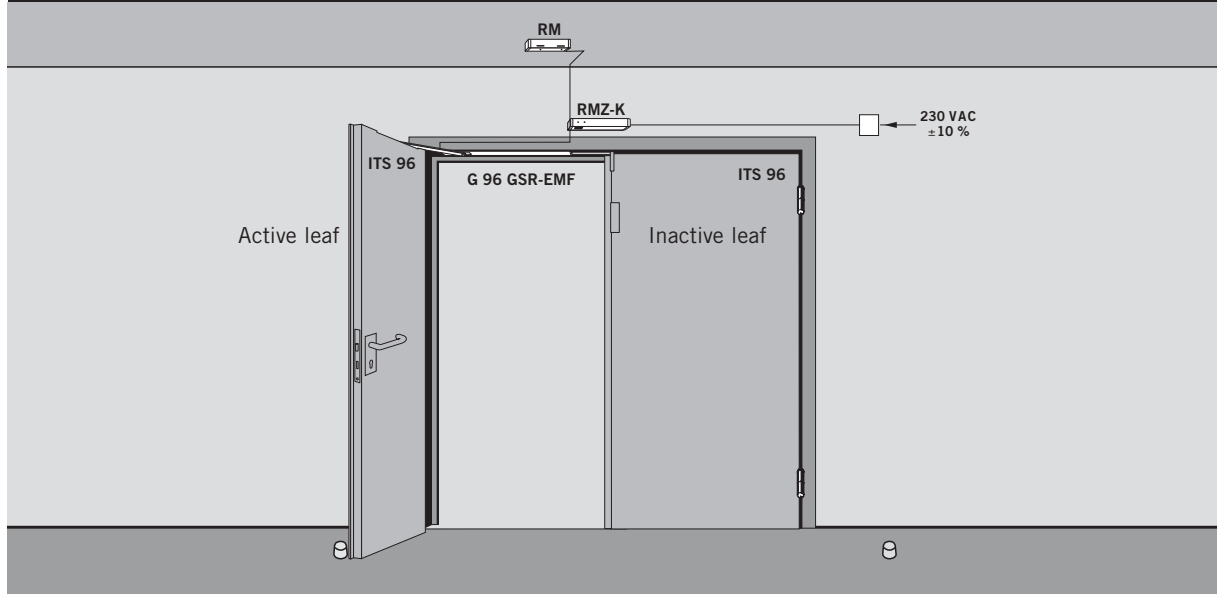

Installation in a timber door

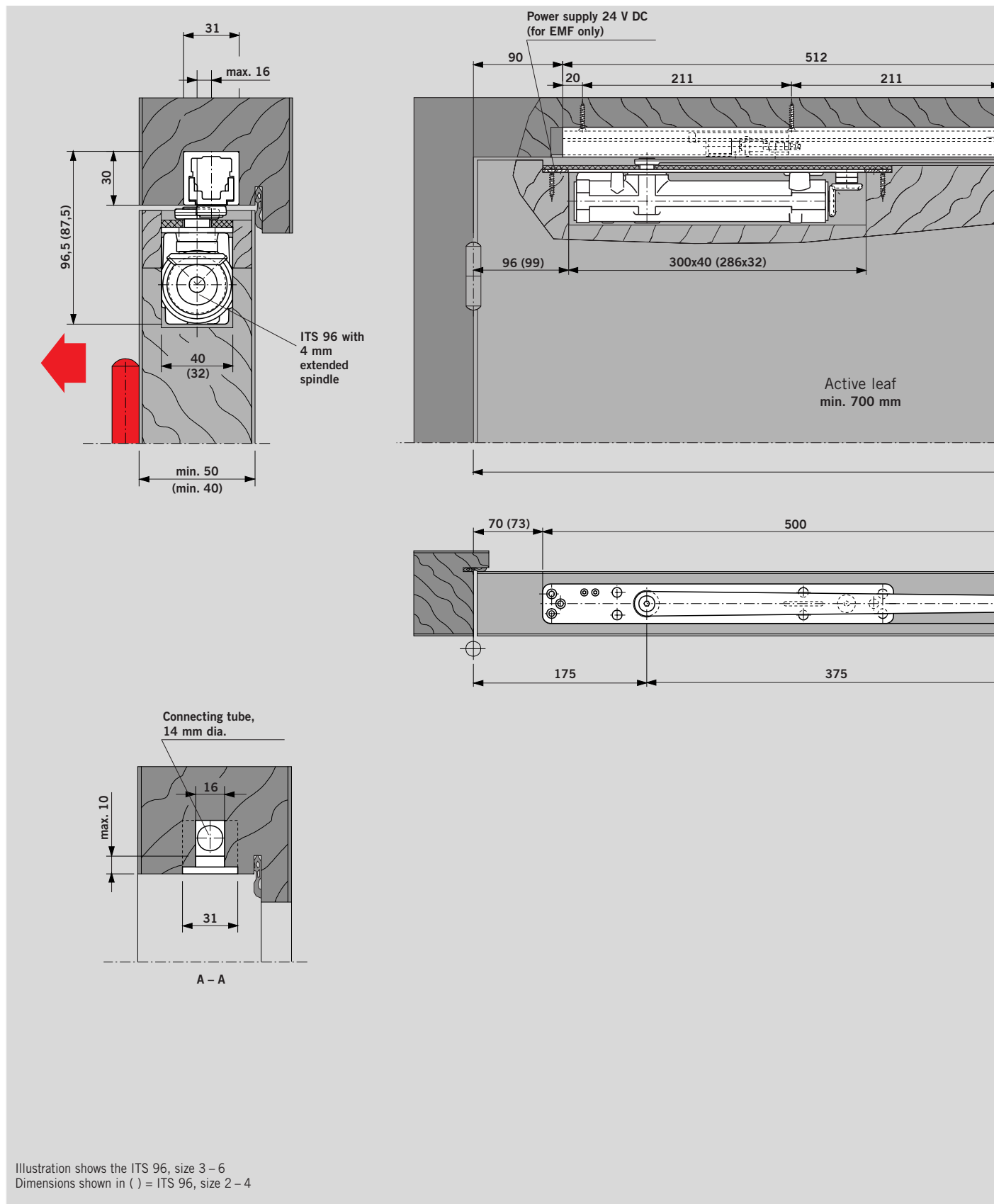

DORMA ITS 96 door closer with DORMA G 96 GSR/GSR-EMF slide channel
Example: Anticlockwise-closing (ISO 6) active leaf; mirror image applies to clockwise-closing (ISO 5) active leaf.

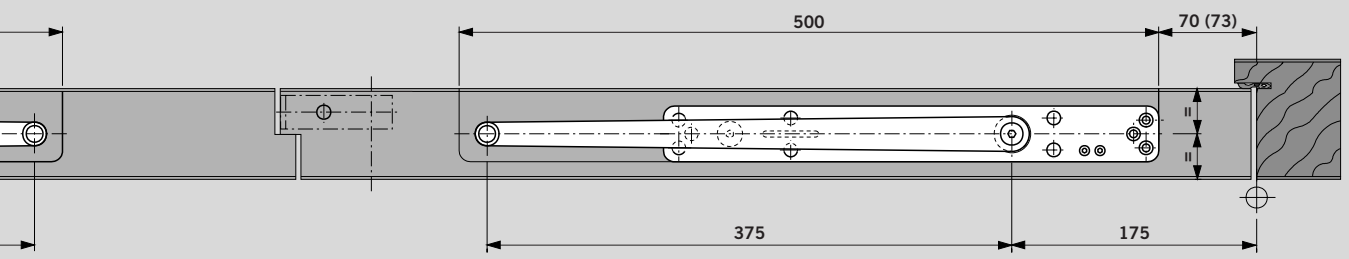
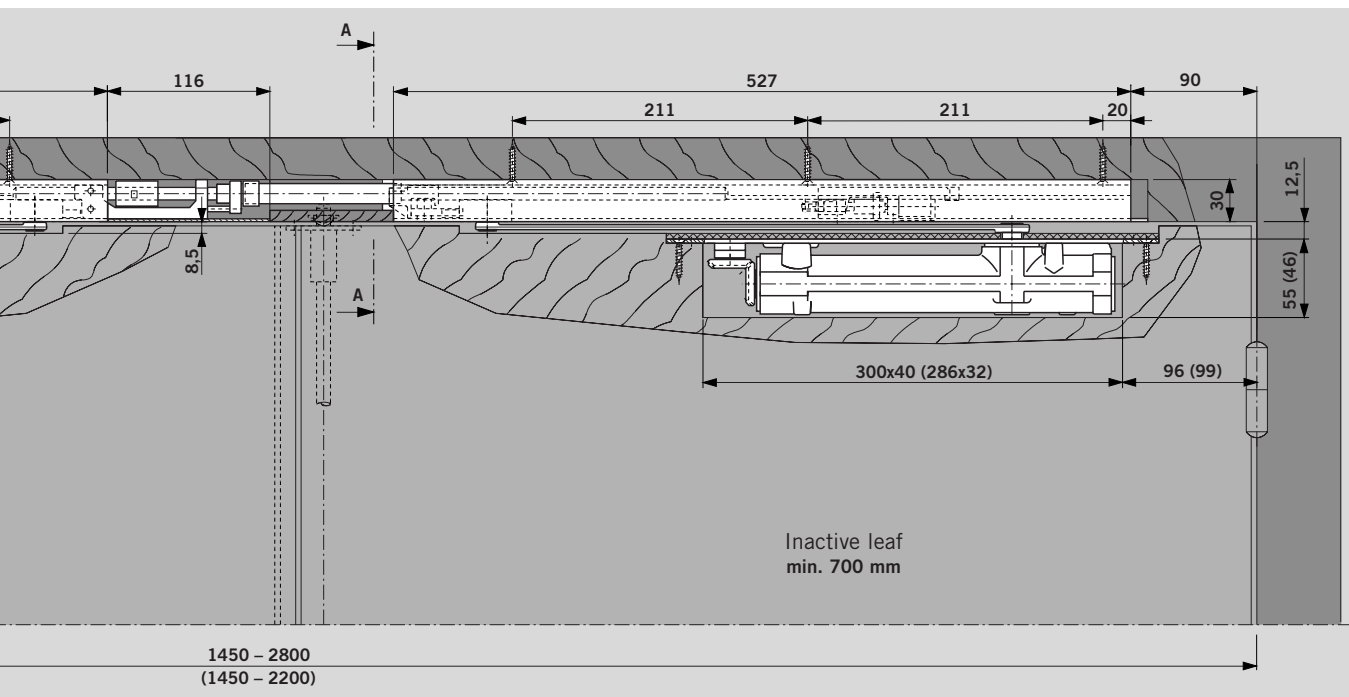

GSR door co-ordinator for **narrow inactive leaf** (inactive leaf slide channel shortened, arm 260 mm)
Inactive leaf 540 - 700 mm
Active leaf min. 750 mm

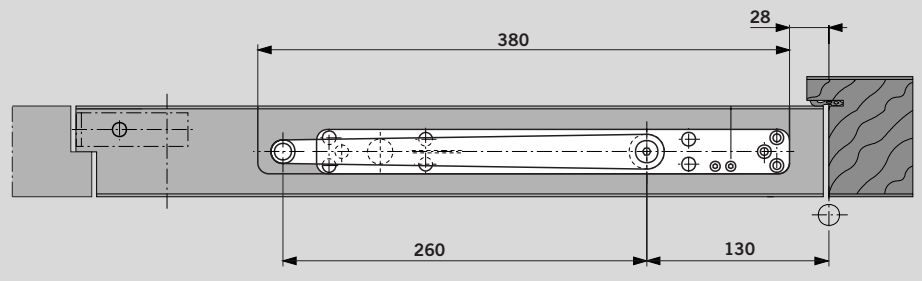
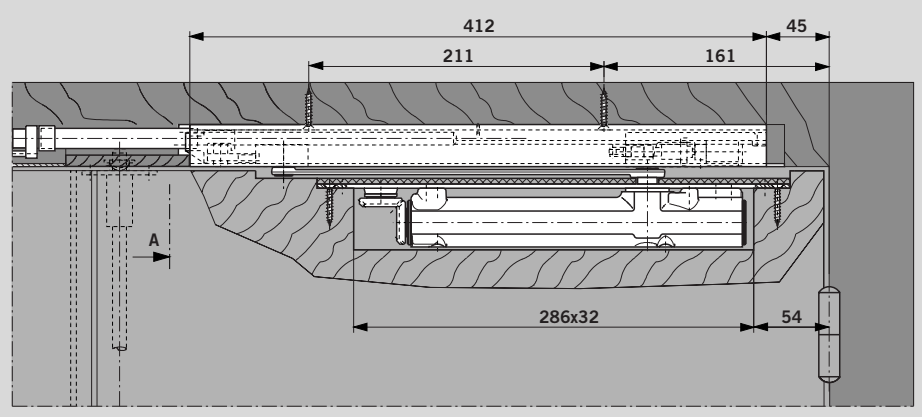

F When installed in fire and smoke check doors, ensure that the DORMA MK 397 carry bar is also fitted.

Installation in an aluminium framed door

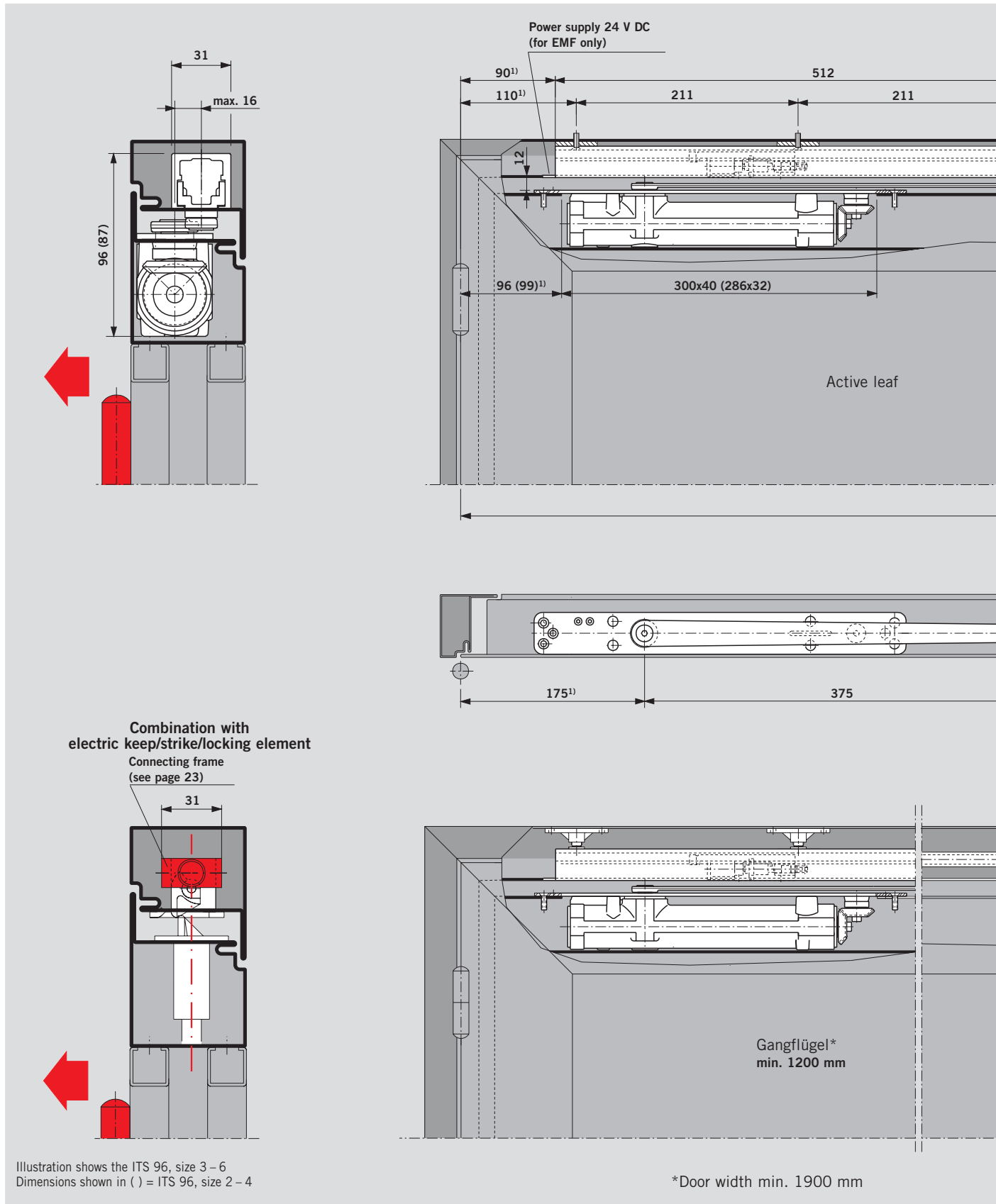

DORMA ITS 96 door closer with DORMA G 96 GSR/GSR-EMF slide channel
Example: Anticlockwise-closing (ISO 6) active leaf; mirror image applies to clockwise-closing (ISO 5) active leaf.

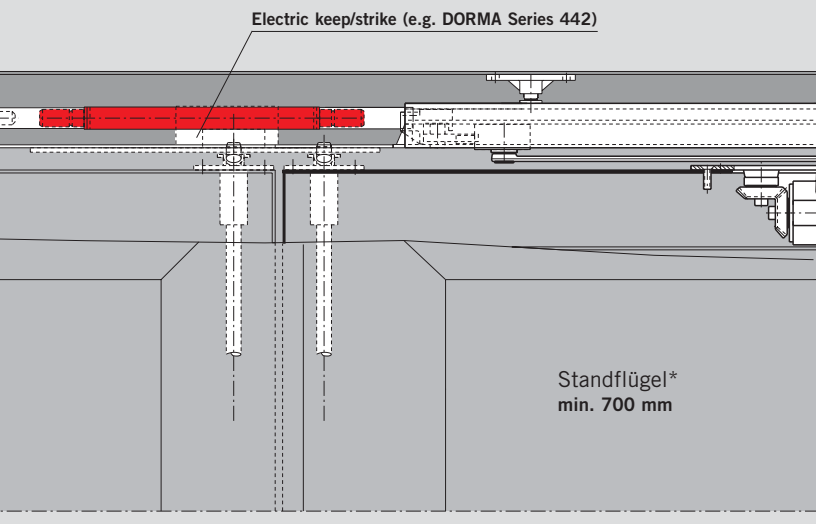
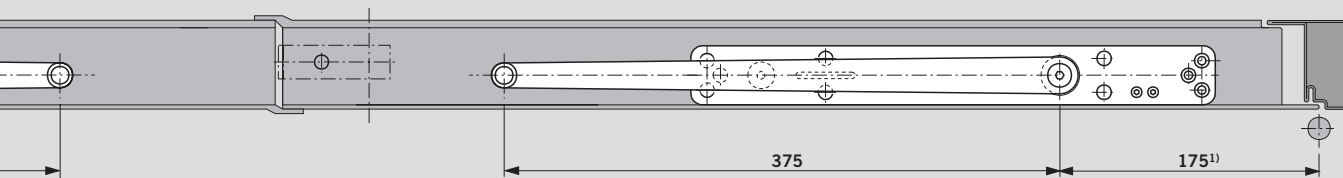
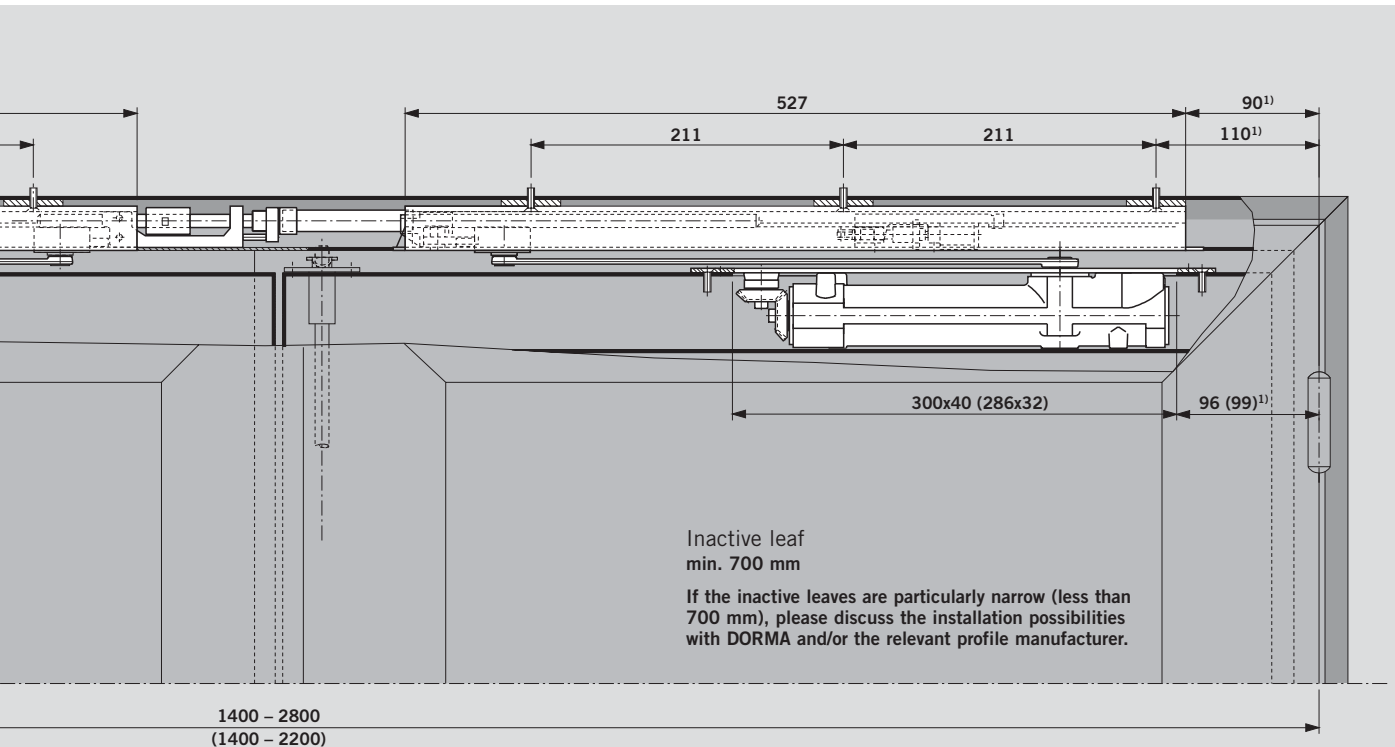

¹⁾ Profile frames with corner angle reinforcement

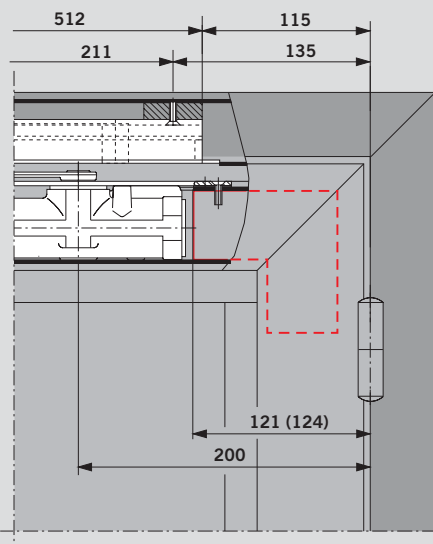

F When installed in fire and smoke check doors, ensure that the DORMA MK 397 carry bar is also fitted.

The DORMA RMZ-K/S frame-mounted smoke detector and the DORMA RM frame and ceiling-mounted smoke detector provide the ideal complement to the successful, service-proven DORMA ITS 96 range of preventative fire protection products. They are designed in accordance with the latest codes issued by the German Institute for Building Technology, and ensure perfect interaction between all the devices employed for holding open fire and smoke doors –

whatever the situation. The innovative design of these devices has ensured a high degree of compactness so that there are no installation or positioning problems. And their attractive Softline styling blends in with any surroundings.

F Approval certification

DORMA RMZ-K/S and DORMA RM units have been approved by the German Institute for Building Technology, Berlin, as hold-open release devices.

DORMA RMZ-K/S

Frame-mounted smoke detector with stabilised power supply unit. This detector is available as an Enhanced or Standard model.

In the event of an alarm or a power failure, this unit de-energises all the hold-open devices connected to it (release function).

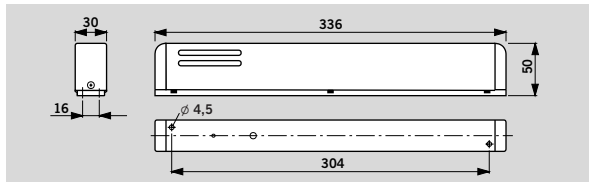

DORMA RM

Designed as a smoke switch; actuates a floating (volt-free) change-over contact in the event of an alarm or power failure.

Also suitable as an add-on smoke detector for the DORMA TS 73 EMR, TS 93 EMR and RMZ. Tested by VdS Cologne to EN 54, Part 7.

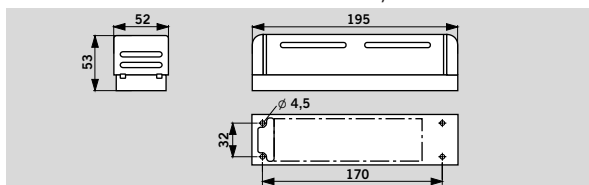

Specification texts

RMZ-K/S

Smoke detector for frame mounting with integrated power supply unit and optical smoke sensor. For release of DORMA hold-open devices. With connections for further smoke detectors. Floating (volt-free) change-over contact and connection terminals for external manual release. Input voltage 230 V AC Operating voltage 24 V DC Approved by the Institute for Building Technology in Berlin as a hold-open release device.

Colour

- silver white, like RAL 9010 9016
- stainless steel
- polished brass
- special colour __ (like RAL __)

Model

- Enhanced model with optional connection of additional detectors, external manual release and floating (volt-free) alarm contact. **Make DORMA RMZ-K**
- Standard model with optional connection of additional 2-wire detectors **Make DORMA RMZ-S**



Data and features		RMZ-K	RMZ-S	RM
Functions	Smoke detector Release device Power supply unit	● ● ●	● ● ●	● ● –
Smoke detection	Scattered light principle (optical sensor)	●	●	●
Fixing	Frame-mounted Ceiling-mounted	● –	● –	● ●
Connection of other detectors	2-wire smoke switches	● ●	● –	● ●
Total installed load (max.) for hold-open device and other detectors in W		4.4	4.4	Depends on power supply unit
Power input of internal detectors in W		0.5	0.5	0.6
Indicators	Alarm – red LED Armed – green LED	● ●	● ●	● ●
Input voltage		230 V AC ± 10 %	230 V AC ± 10 %	24 V DC +15%, -10%
Output voltage		24 V DC	24 V DC	24 V DC
Detector operating voltage		24 V DC	24 V DC	24 V DC +15%, -10%
Input current (max.) with external power supply unit, in A		–	–	2
Current input (max.) in mA		111	91	25
Floating change-over contact	Switching voltage (max.)	60 V DC/ 25 V AC	–	60 V DC/ 25 V AC
	Switching current (max.)	2 A	–	2 A
	Switching capacity (max.)	60 W	–	60 W
Automatic reset can be change to manual reset		● –	● –	● ●
Test port for functional checking		●	●	●
Connection terminals for external manual release		●	–	●
Degree of protection		IP 20	IP 20	IP 20
Ambient temperature in °C		–15, +60	–15, +60	–20, +50
Weight in kg		0.6	0.6	0.4
Dimensions in mm	Length	336	336	195
	Overall depth	50	50	53
	Height	30	30	52

● yes – no

For more detailed information, see RMZ/RM brochure

RM

Non-directional, universal optical smoke detector (24 V DC) for frame and ceiling installation. Can be employed as smoke switch and monitoring device for hold-open devices. With connections for further smoke detectors, floating (volt-free) change-over contact and connection terminals for external manual release. Approved by the Institute for Building Technology, Berlin for general use as a hold-open release device and tested by the VdS Cologne to EN 54 Part 7.

Colour

- silver white, like RAL 9010 9016
- stainless steel
- polished brass
- special colour __ (like RAL __)



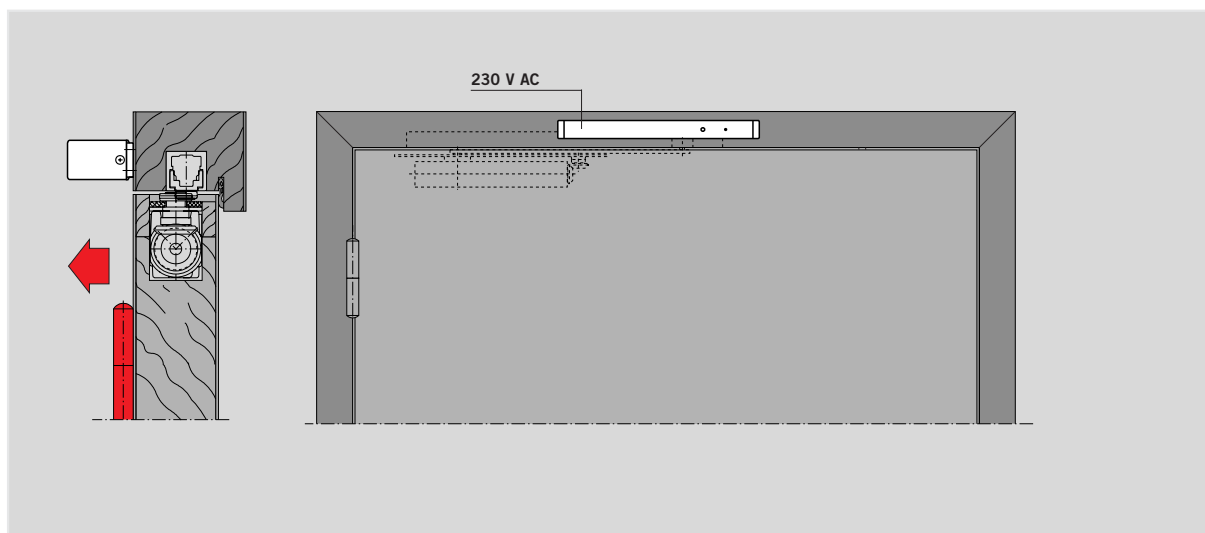

RMZ-K/S frame-mounted smoke detector on the pull side connected to an ITS 96 EMF
 Example: Anticlockwise-closing (ISO 6) door; mirror image applies to clockwise-closing (ISO 5) doors.

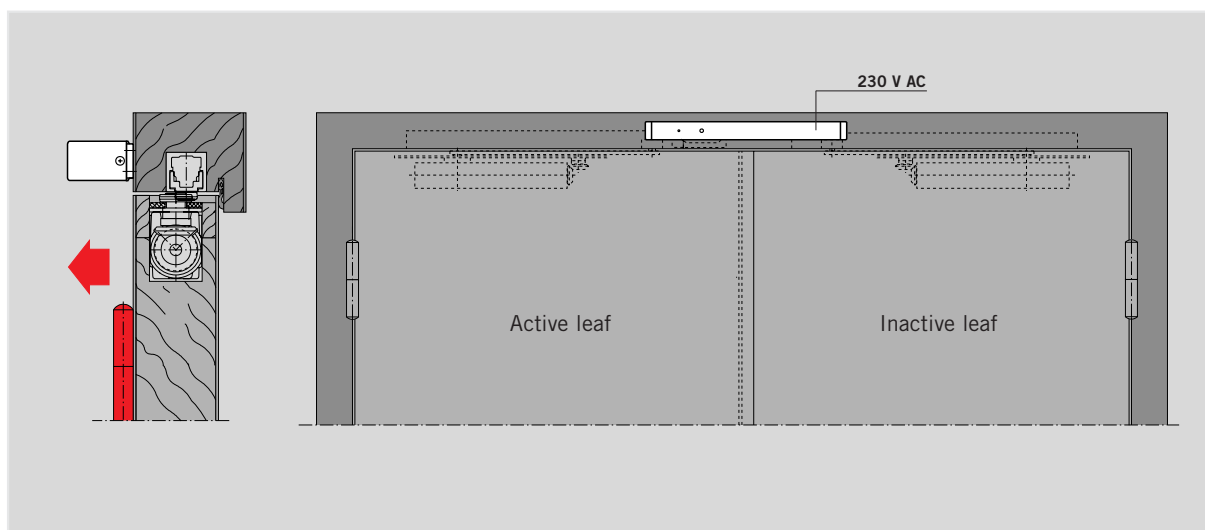

RMZ-K/S frame-mounted smoke detector on the pull side connected to an ITS 96 GSR-EMF
 Example: Anticlockwise-closing (ISO 6) active leaf; mirror image applies to clockwise-closing (ISO 5) active leaf.

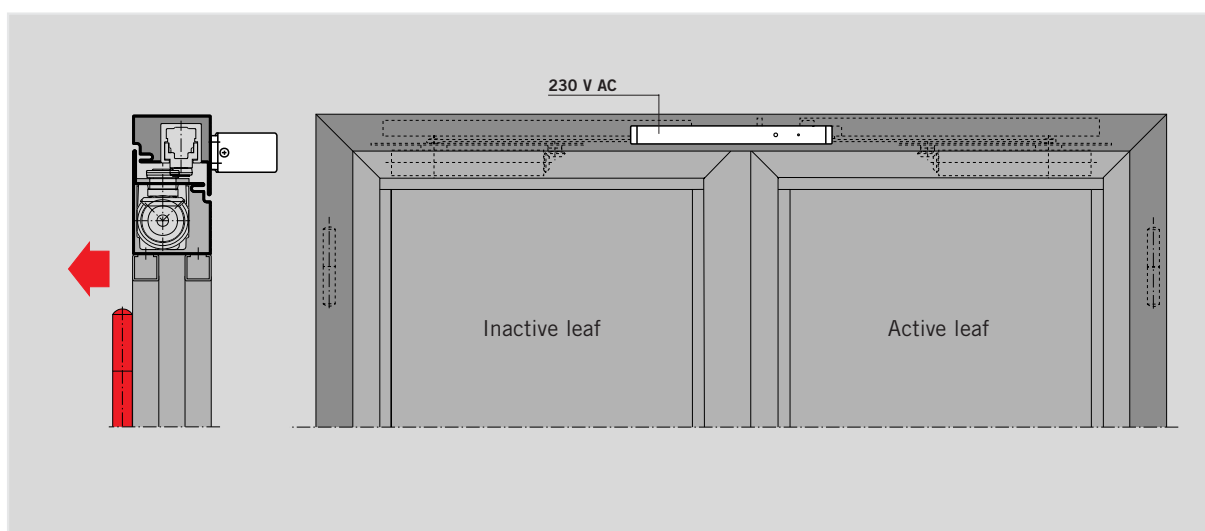

RMZ-K/S frame-mounted smoke detector on the push side connected to an ITS 96 GSR-EMF
 Example: Anticlockwise-closing (ISO 6) active leaf; mirror image applies to clockwise-closing (ISO 5) active leaf.

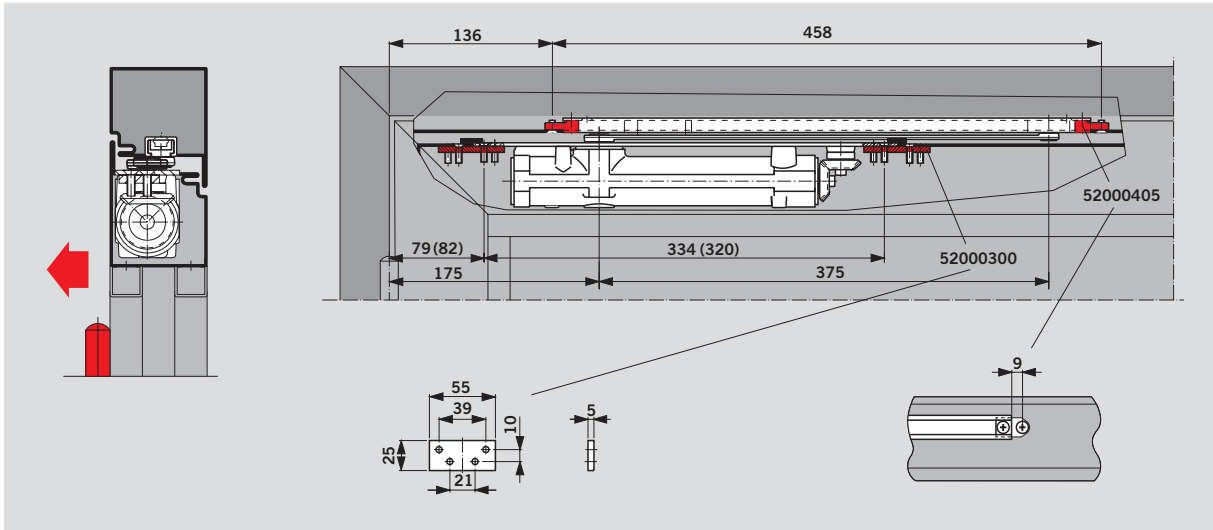

Fixings for **G 96 N20** and mounting plate for ITS 96

Example: Anticlockwise-closing (ISO 6) door; mirror image applies to clockwise-closing (ISO 5) doors.

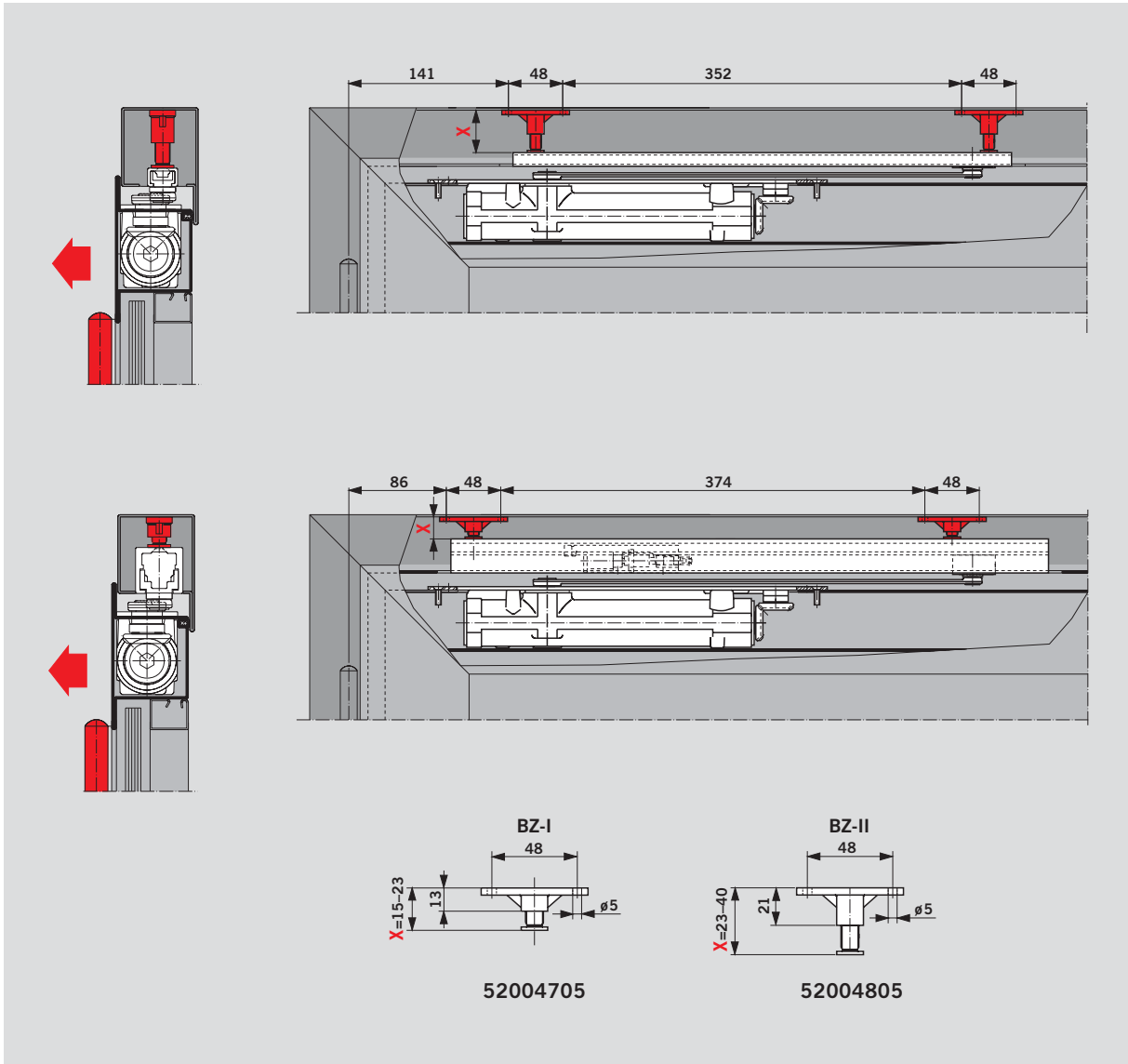

Fixings for height adjustment in relation to **G 96 N20, EMF, GSR**

Example: Anticlockwise-closing (ISO 6) door; mirror image applies to clockwise-closing (ISO 5) doors.

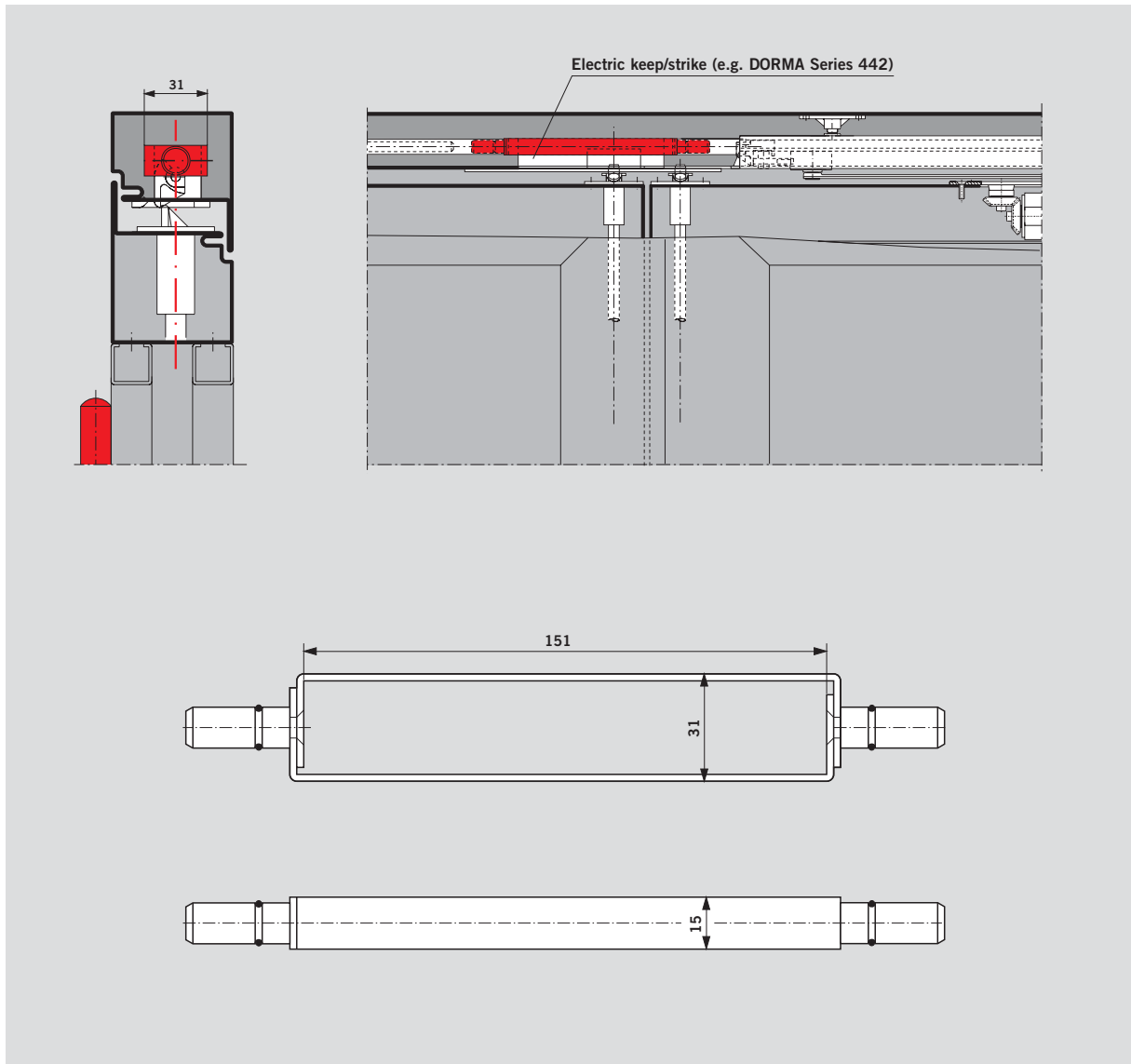

Connecting frame for **G 96 GSR** door co-ordinator for use on doors with electric keep/strike or overhead electromechanical locking element (see page 18)

*Door width min. 1900 mm

If the DORMA G 96 GSR door co-ordinators are required to operate independently of the ITS 96 door closers, e.g. in combination with the ED 200 automatic swing door operator, the connection between the door co-ordinator and the door leaf is provided by means of GSR pivot blocks.

Specification text

Pivot bearing for closer-independent door co-ordination with DORMA G 96 GSR door co-ordinators.

Make
DORMA ITS GSR pivot block

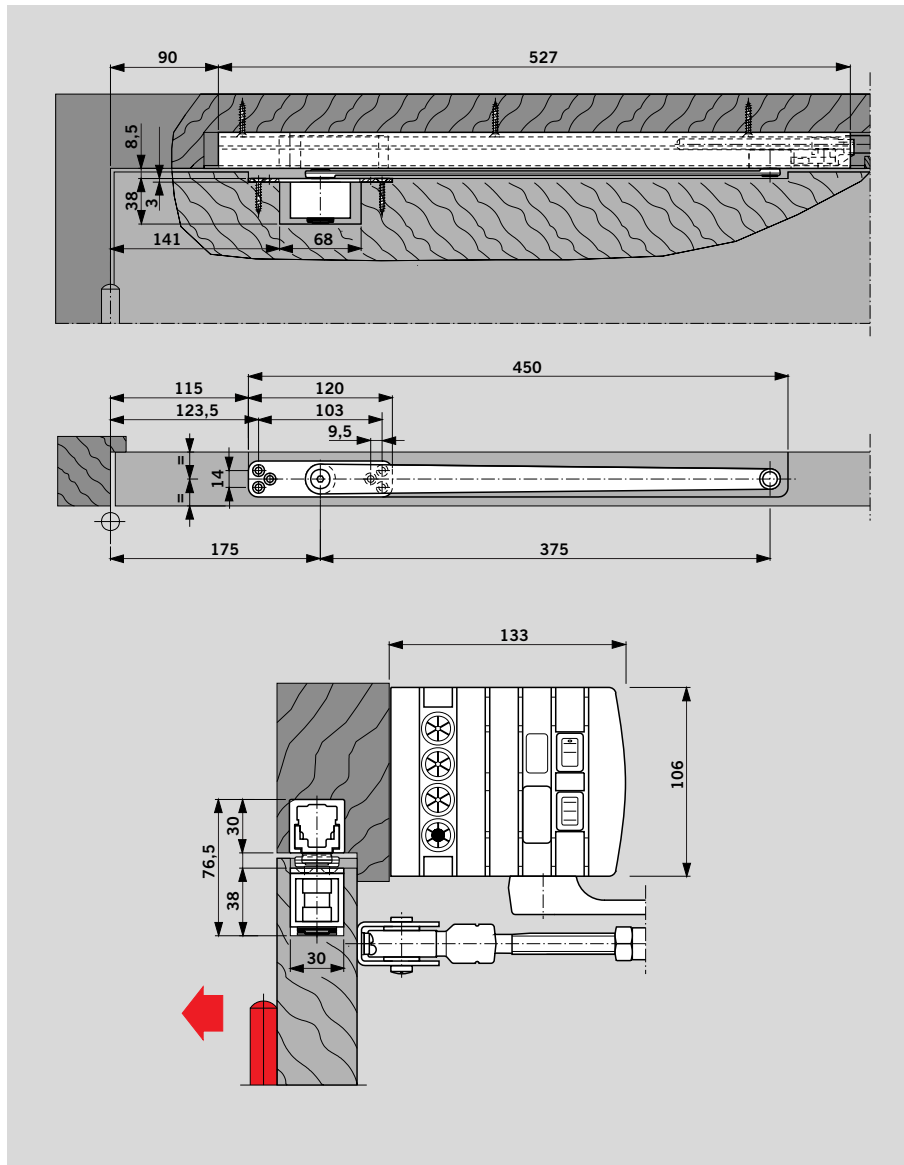

The pivot bearing used in conjunction with the G 96 N20 slide channel also acts as a **cushioned limit stay**.

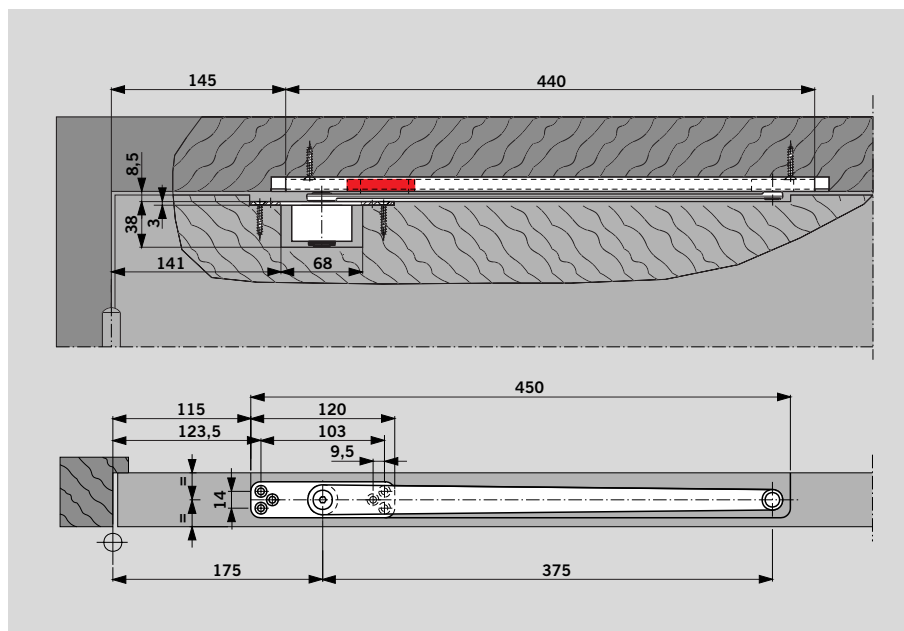

The use of hold-open devices may be subject to certain conditions. These usually deal particularly with the relevant acceptance, routine inspection and maintenance requirements.

The information given on this page is designed to inform all relevant persons of the most important measures to be implemented in order to ensure best practice governing the operation of hold-open systems.

Further details can be found in the following documents:

- Guidelines for hold-open systems, published by the German Institute for Building Technology, Berlin.
- Building Regulations, England and Wales
- Other national building regulations
- general building regulations approval of the hold-open system concerned
- EN 1155

1 General

1.1 In respect of doors etc. which are held open by hold-open systems, the area needed for closure must be kept permanently free of obstructions. This area should be clearly indicated by means of lettering, floor markings or similar. If necessary, structural measures may need to be

taken in order to ensure that wiring/ducting, stored goods or structural components (e.g. false ceilings or other components) do not fall down into the area to be kept clear.

1.2 As far as possible, smoke detectors should be used for hold-open systems.

Smoke detectors should be used for hold-open systems for doors etc. in emergency exits and escape routes.

1.3 All hold-open devices should allow manual release without their operational readiness being adversely affected. Door closers with electro-magnetic hold-open

systems can be released by pressing lightly on the door leaf. If hold-open magnets or free-swing door closers are used, the release function is triggered by pressing a switch. The switch must be located in the immediate proximity of the door and must not be covered when the door is held open.

2 Commissioning

2.1 After the system has been fitted ready for use on site, it should be commissioned to check that its operation is problem-free and that its installation complies with all relevant regulations. The commissioning should only be performed by qualified technical personnel.





3 Routine Inspection

3.1 The operator should keep the hold-open system in a permanently fit state for use and must inspect it at least once a month to ensure its functional integrity.

3.2 In addition, it is the responsibility of the operator to ensure that all devices are checked and maintained/serviced to ensure their combined functional integrity, this to be performed at least

once a year, unless a shorter time period is stipulated in the national regulations. This inspection and servicing activity should only be carried out by a specialist or suitably qualified person.

3.3 The scope, result and time of the routine inspections should be recorded, and these records should be retained by the operator.

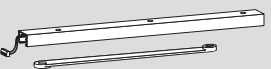
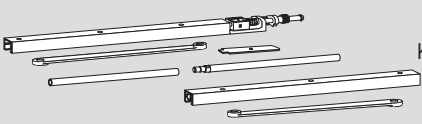
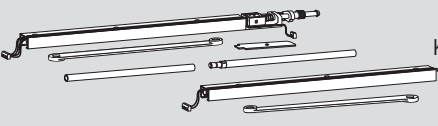
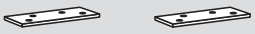
	ITS 96	ITS 96 with 4 mm extended spindle	ITS 96 with 8 mm extended spindle
	 EN 2 – 4 ■ 52400150 EN 3 – 6 ■ 52250150	 EN 2 – 4 ■ 52410150 EN 3 – 6 ■ 52260150	 EN 2 – 4 ■ 52420150 EN 3 – 6 ■ 52270150
For specification text/product description, see page	4	4	4
G 96 N20  L □ 52003701 K8/K12 R □ 52003801	8		
G 96 EMF  L □ 52001501 K8/K12 R □ 52001601	10		
G 96 GSR  □ 52001801 K8/K12 260 ¹⁾ □ 52004001	12	2x	2x
G 96 GSR-EMF  □ 52001701 K8/K12 260 ¹⁾ □ 52004201	14	2x	2x
Fixing plates for ITS 96  52000300	22	#	#

■ = Closer body separate







□ = Slide channel separate

= Optional accessory

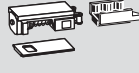
L =  LH/anticlockwise closing (ISO 6)

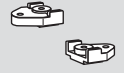
R =  RH-clockwise closing (ISO 5)

¹⁾ GSR door co-ordinator for inactive leaf of 540–700 mm (inactive leaf slide channel shortened, arm 260 mm)

RF hold-open unit for G 96 N	RF hold-open unit for G 96 GSR, inactive leaf	Fixing BZ I for narrow-stile/alu-framed doors	Fixing BZ II for narrow-stile/alu-framed doors	Fixings for mounting the G 96 N20 aluminium doors	Connecting frame for G 96 GSR	Pivot bearing	Carry bar MK 397
							
K8/K12 52005600	K8/K12 52003500	52004705	52004805	52000405	52004400	52003400 ¹⁾	470029xx ²⁾
8	–	22	22	22	23	24	
#		#	#	#		#	
#		#	#	#		#	
		#	#				
		#	#				
	#	#	#		#	#	#
	#	#	#		#	#	#
		#	#		#		#
		#	#		#		#

Smoke detector system

RMZ-K
180619xx



RM
3570xx88



RMZ-S
180618xx

Colour	xx		
silver	01	Stainless steel	
white (RAL 9016)	11	“Design” finish	04
white (RAL 9010)	10	polished brass	05
Special colour	09		

For specification text/product description, see page 20

¹⁾ Pivot bearing with 4 mm and 8 mm extended spindle available on request

²⁾ MK 397 Colour xx
galvanised 00
special colour 30

Your Partners Worldwide

DORMA GmbH + Co. KG
Division Door Control
www.dorma.com

Australia

DORMA Door Controls Pty. Ltd.
P.O. Box 1092
Narre Warren Vic 3805
52 Abbott Road
Hallam/Victoria 3803
Australia
Phone: +61 3/97 96 35 55
Fax: +61 3/97 96 39 55

Central Europe

DORMA GmbH + Co. KG
Postfach 40 09
D-58247 Ennepetal
Phone: +49 23 33/7 93-0
Fax: +49 23 33/7 93-4 95

Emerging Markets

DORMA GmbH + Co. KG
Postfach 40 09
D-58247 Ennepetal
Phone: +49 23 33/7 93-0
Fax: +49 23 33/7 93-4 95

Far East

DORMA Door Controls Pte. Ltd.
No. 2 Jalan Terusan
Jurong
Singapore 619285
Phone: +65 6268/76 33
Fax: +65 6265/79 95

France

DORMA France S.A.S
Europarc
42/44, rue Eugène Dupuis
F-94046 Creteil Cedex
Phone: +33 1/41 94 24 00
Fax: +33 1/41 94 24 01

Gulf

DORMA Gulf Door Controls FZE
Jebel Ali Free Zone,
Roundabout 8,
Unit VC 02, P.O. Box 17268
Jebel Ali
Dubai, United Arab Emirates
Phone: +971 48/83 90 14
Fax: +971 48/83 90 15

DORMA Group North America

DORMA Door Controls
DORMA Drive
Reamstown, Pa. 17567, USA
Phone: +1717/3 36 38 81
Fax: +1717/3 36 21 06

ScanBalt

DORMA Danmark A/S
Sindalvej 6 – 8
DK-2610 Rødovre
Phone: +45 44/94 30 77
Fax: +45 44/94 95 04

South Africa

DORMA Door Controls (Pty.) Ltd.
Kings Court
Southdale
2135
Johannesburg
South Africa
Phone: +27 11/8 30 02 80
Fax: +27 11/8 30 02 91

South America

DORMA Sistemas de Controles
para Portas Ltda.
Av. Piracema, 1400
Centro Empresarial Tambore
CEP 06400 Barueri/
São Paulo, Brasil
Phone: +55 11/41 91 22 38
Fax: +55 11/41 91 22 83

South-East Europe

DORMA AUSTRIA GmbH
Pebering Strass 22
A-5301 Eugendorf
Phone: +43 62 25/86 36-0
Fax: +43 62 25/79 68

South Europe

DORMA Italiana S.r.l.
Via. A. Canova 44/46
I-20035 Lissone (MI)
Phone: +39 039/24 40 31
Fax: +39 039/24 40 33 10

DORMA Ibérica, S.A.
Camino San Martín de la Vega, 4
E-28500 Arganda del Rey
(Madrid)
Phone: +34 91/8 75 78 50
Fax: +34 91/8 75 78 81

IRL – Irland*

DORMA Door Controls Ltd.
19, Sandford Office Park
Foxrock
IRL-Dublin 18
Phone: 00353 1/2 95 82 80-82
Fax: 00353 1/2 95 85 84

